



CELİKEL
THE CHOICE OF PROFESSIONALS



2020

BRASSUS

Double Auger Horizontal Feed Mixers (5-20 m³)

18

BRASSUS MICRO

Double Auger Horizontal Feed Mixers (2-5 m³)

24

CHARGER

Vertical Feed Mixers (8-55 m³)

28

CHARGER MICRO

Vertical Feed Mixers (0,75-6 m³)

32

CHARGER TESLA

Stationary Vertical Electric Powered Feed Mixers(16-55 m³)

36

CHALLENGER I

Single Row Forage Harvesters

44

CHALLENGER II

Double Row Forage Harvesters

46

We are the company, who is encouraged by its past and looking confidently into the future in agriculture and livestock farming sector. At Çelikel, we develop industry-leading products to help you scale your business and achieve stellar results. We play the team sports but in the original way. We set the rules of the game.



CHALLENGER III

Three Row Forage Harvester

48

CHALLENGER IV

Four Row Forage Harvester

50

CALABRIA

Double Chop Forage Harvesters
(1500-2100 cm)

52

PERPETUAL & PERPETUAL GO

Semi-Mobile, Single and Double
Stationed Packing Systems

60

PERPETUAL ULTIMATE

Full-Automatic, Single and
Double Packing lines

62

CRAFTER

Solid Manure Spreaders
(7-18 m³)

70

CRUISER

Liquid Manure Spreaders
(3.000-20.000 lt)

72

SCUD

Manure Management Equipment;
Separators, Scrapper and Pumps
(40-60 m³/hour)

74

leks

ÇELİKEL IN NUMBERS



250
EMPLOYEES
% 20 White Collar
% 80 Blue Collar

40.000
PRODUCTION AREA
Closed Area 30.000 m²
Open Area 10.000 m²



30.000
NUMBER OF MACHINES
PRODUCED PER YEAR

%98
PRODUCTION
IS MADE ON
OUR FACTORY



100+
EXPORT
TO 6 CONTINENTS,
MORE THAN 100
COUNTRIES.

1.
BIGGEST PRODUCER OF
FEED MIXERS IN THE
WORLD.



75 hp
FIRST ROW FORAGE
HARVESTER WHICH ONLY
REQUIRES 75HP.

ISO 9001
CERTIFICATE AND
CE EUROPEAN
MARKING





We offer the best solutions
to meet the needs of our
customers. We are well-
known in Turkey and many
other countries because
of our innovative approach
to work. We encourage
our clients to set the most
audacious goals. Having
realized the potential
needs, we apply our cutting-
edge technologies and
methods to design the next
generation machines FOR
PROFESSIONALS

SINCE 1962

DYNAMIC YELLOW



The nobleness of black or the energy of yellow?

Now you can make a choice! After several years of production in yellow color, now we are ready to present our machines in the noble black. ÇELİKEL graphical designers created the base of machines in matt black color and the stickers are now in yellow and white colors. The rest is up to the customer to decide. This way we combined the strength of the bull in black and the dynamism and energy in yellow color which are the essentials of Çelikel legend DNA.



DARK AS
NIGHT
STRONG AS
BULL



manufactured by *Celikel*

TOYO R1T

TOYO R1T

**NOBLE
BLACK**

M I L E S T O N E S

1980

FIRST EXPORT

The power of Çelikel®'s production went beyond the borders and set off on the adventure of export.

1962

FIRST SWING OF HAMMER

Muhsin TURKMEN hit the red-hot steel with a hammer for the first time in the province of Bogazliyan, Yozgat.

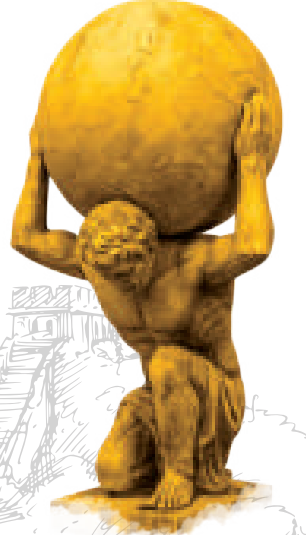
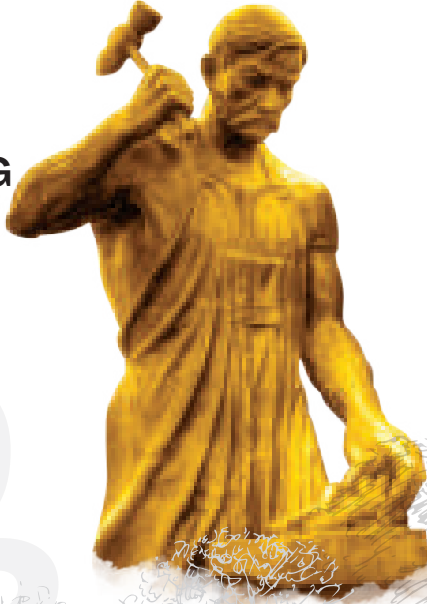

1963

FIRST PRODUCT

Under the guidance of our founder Mukhsin TURKMEN, the steel plow handle touched the ground.



1993

A NEW PRODUCTION CENTER

Çelikel® production center moved to Konya due to its logistics advantages.





2016

RECORD-BREAKING YEAR

This year Çelikel® not only celebrated 50 years anniversary in the machine production but also got in the list 100 fastest – growing companies (TOBB). Do you think this is just a coincidence? This year Çelikel® also broke the record, becoming one of the largest tax payers.

1997

FIRST STEPS TO LIVESTOCK

In addition to the agricultural machinery, Çelikel started the production of livestock farming machines.



2003

BIRTH OF FEED MIXERS

Çelikel® started producing feed mixers. This start was the first step of becoming the biggest feed mixer producer.



2017

100 COUNTRIES IN EXPORT

Being as fearless as we are at Çelikel®, we reached 100 countries in export, and what's more, Çelikel® also was selected as one of the 50 most innovative company in Turkey in the inovaLIG 2017 ranking.

2017

PRODUCTION CENTER



Day here begins when 250 men with the hearts of steel enter the site. Manufacturing top quality machines is a mixture of a hard work and creativiyy. At Çelikel® we are passionate about providing high quality machines. With our products, you can always stay ahead of the curve.

40.000
S Q U A R E M E T E R S

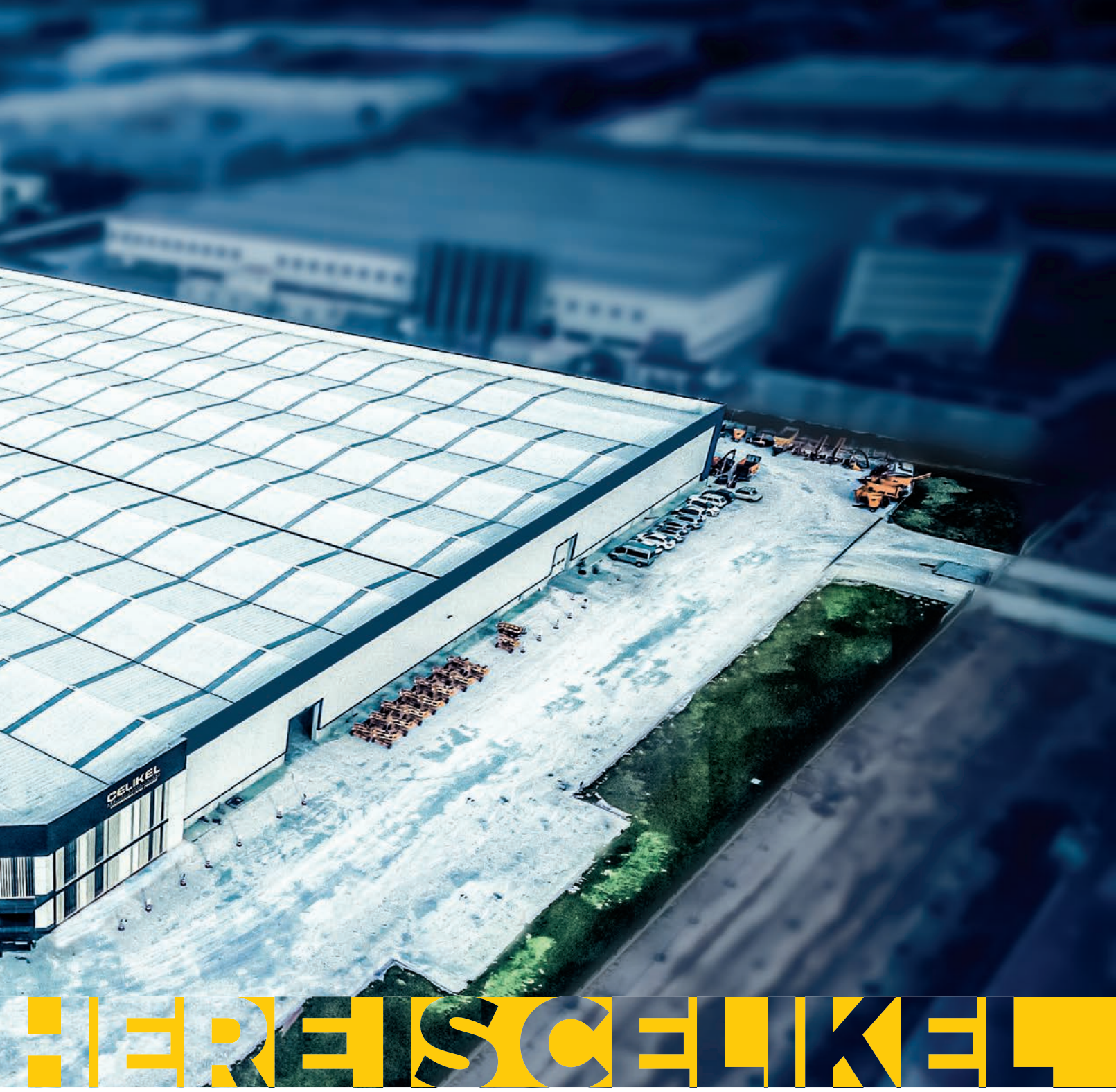

This is the place where the combination of professionalism and art is embodied into machines. At the very heart of the ÇELİKEL legend, exceptionally strong and robust machines are being produced. Have you ever wondered how a re-

sult-oriented, constantly evolving factory with an experience of 4 generations works day after day. Our doors are open and we are ready to welcome you at our factory. We know at least 250 people who would be happy to see you drop by.

PRODUCTION CENTER



Carrying out all the stages of production, from the very start to the quality control, Çelikel team makes sure that our customers get off to a great start and keep the momentum high.

Çelikel® team is always very careful with both production and the quality control processes so we can guarantee that our clients will not have to deal with any problems while using our machines.



Production system in Çelikel® is based on JIT “Just-in-time” and KANBAN methods. Here we use the most modern and technological hardware. Thanks to the company’s large machine park, 98% of all the work processes are being made on our own facility. That is why we can guarantee high quality as well as fast and flexible production.

PRODUCTION CENTER



We play the team game in our own unique way. We set the rules of the game. Every product that comes out of our production center is a part of our game. The fact that you can see the footprints of Çelikel® in so many countries and continents is not a coincidence.

We are the company, who is encouraged by its past and looking confidently into the future in agriculture and livestock farming sector. At Çelikel, we develop industry-leading products to help you scale your business and achieve stellar results. We play the team sports but in the original way. We set the rules of the game.



R & D C E N T E R

Çelikel's innovative style and rich experience in machine production enables the implementation of results-oriented design strategies.

All research at the Çelikel R&D center is carried out by over 20 competent engineers striving for excellence. These processes involve programs such as PDM, CAD \ CAM and SOLIDWORKS. The ability to develop production makes Çelikel® a leading company both nationally and globally.



EXPORT

Çelikel®'s international trade processes are carried out in 8 foreign languages. Due to our constantly expanding sales and distribution channels, all the stages of export processes are running very smoothly.

In today's highly competitive market, you can not afford to skimp on quality. With our products, you can always stay ahead of the curve. At ÇELİKEL® we make sure that our production processes meet stated quality and standardization conditions. Quality and a longer lifespan for our products are inseparable core values. This is what makes us different from our competitors.

Çelikel® production has reached 100 countries from Asia to America, and Europe to Africa, around 6 continents due to its effective sales.



FUTURE

VISION

OUR
VISION
OF

We are results-driven, dynamic and constantly developing organization with many years of experience.

WE SHAPE THE FUTURE OF AGRICULTURE.

Nowadays our world is losing its arable land due to erosion or pollution. This leads to potentially disastrous consequences like global demand for food and basic nutrients as the humankind population is increasing just as much. We strive to meet needs of people by providing agricultural mechanization and automation. Our goal is to provide the basic nutrition needs for humankind by playing the role model in automatization and mechanization of agriculture.

We offer the best solutions to meet the needs of our customers. We are well-known in Turkey and many other countries because of our innovative approach to work. We encourage our clients to set the most audacious goals. Having realized the potential needs, we apply our cutting-edge technologies and methods to design the next generation machines FOR PROFESSIONALS.



FEED MIXERS



DARK AS STRONG AS

There is no such machine that could be compared with Brassus®

There still is not enough said about BRASSUS® despite being the most preferred feed mixer of the World for the last three years in a row.

BRASSUS has an innovative and easily recognized BLACK & BOLD gear group with 26 bolts strength. The performance of BRASSUS is complemented by a perfect matte black design. Brassus does its best to be more compassionate towards its competitors, but other machines have only dreamed of growing up and becoming a BRASSUS one day!



NIGHT AS A BULL

Brassus

FEED MIXERS

Çelikel started manufacturing machines for livestock farming after having realized the needs of livestock production businesses years ago. Then Çelikel developed Brassus®: The easiest way of preparing homogeneous mixed ration.

Brassus® feed mixers which are manufactured in 2-3-4-5-6-8-10-12-14-16-18-20 m3 capacities are offering solutions to large and small scaled businesses' who are in engaged in feed

preparation processes. Thanks to fast and high quality feed distribution system; all the animals are supplied with as much feed as they need for their own potential and needs. By purchasing BRASSUS® feed mixer, you get yourself a dependable, high performance machine specially designed to meet your needs. BRASSUS® promises you all the advantage required for a farm to be competitive with its extraordinary design and powerful structure.



BLACK BOX OF SAVING

The Blackbox has been developed by Celikel's R&D team to meet the expectations of our farmers in terms of cost savings on feed mixer machines.

Blackbox® is an electrical power transmission system that will increase the profitability and reduce fuel consumption by up to 78%. You can save on fuel costs by using this system, which makes it possible to use electrically powered feed mixer machines without having to separate it from the tractor regardless of the model.

Blackbox® can be used in all vertical feed mixers regardless of the brand and model.

Blackbox® makes it possible to use the machine with both a tractor and an electric motor. You may start your machine by plugging it to the nearest electricity outlet after filling the feed as usual, mix it and then you can serve the feed to your livestock after you disconnect the power cable.

BLACKBOX



Black & Bold; has been designed to prevent any kind of power loss.

There is NOT a single company which would offer you Black & Bold transmission technology apart from ÇELİKEL. Being a machine is easy, but what is more difficult is being BRASSUS®! We have no doubt that the tractor you are using will envy the power of Black & Bold transmission. You may doubt yourself, but BRASSUS®? Never.

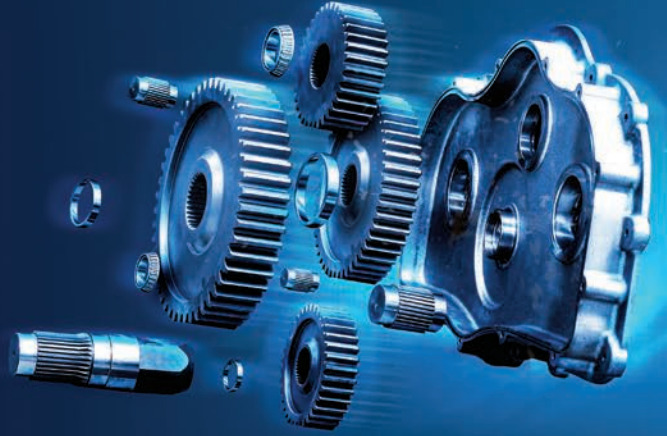

■ REINFORCED CHASSIS

You will see the sturdy Brasuss chassis under its remarkable design and solid structure.



■ DIGITAL WEIGHT SYSTEM

Digital weighing system is capable of storing up to 12 different mixes and 48 different feed ingredients.

FEED MIXERS

Having realized the needs of livestock farmers, Çelikel has started to produce machines for livestock farming. Çelikel has developed the easiest way to produce homogeneous feeding mixed ration - the Brassus®.



■ WIDE TREAD TYRES

Çelikel® wants its machines to be flawless in the direst conditions. All the machines of Çelikel® have resistant, strong, innovative, anti soil-compaction wheels.

■ AUGER SYSTEMS

Powered by two counter-rotating augers, Brassus provides the most efficient rations by chopping raw, stinky materials such as stems, stalk, hay and clover. The simultaneously twisting augers work with the help of shredding and mixing paddles. Spiral blades located at the edges of the augers transfer the feed to the center and circulate the feed in the chamber.

■ INDEPENDENT HYDRAULIC SYSTEM

Independent hydraulic system makes it possible to use the machine's hydraulic parts without the tractor's oil pressure. This will save you fuel and time.





DIGITAL WEIGHT SYSTEM

Digital weight system can store up to 12 different mix and 48 different feed materials in its memory.

Brassus



■ HYDRAULIC BUCKET

New loading bucket is designed to load all kinds of feed (such as stalk, clover, hay bales, silage, beet pulp, wet feed, scientific feed, granule feeds and etc.) and what's more it saves time.

■ CONVEYOR

Due to its symmetrical design, discharge conveyors and windows can be positioned on both sides, feed discharging process can be made in one or both sides. The discharge conveyors are available in lengths 80 cm - 100 cm - 140 cm.

■ COMPACT STRUCTURE

Çelikel engineers combined functionality with visibility in our new generation feed mixer, Brassus®. In the compact Brassus® design all the hydraulic and electronic devices are assembled under the front cover. Brassus® feed mixed ration not only makes your animals happy but also increases the value of your farm.



FEED MIXERS

The history of feed mixers has started with Biomix, continued with Probiomix, improved with Charger and completed with BRASSUS®. BRASSUS® is the ultimate word in the history of feed mixers!



■ BLACK&BOLD TRANSMISSION

Legendary BLACK&BOLD transmission gearbox body is a combination of smelted red steel, silicium, magnesium and three different elements. These parts of the machines are assembled together with special engineering techniques under the monolithic cover. As a result, we can see a work of art by Çelikel® engineers. Our stretch resistant transmission gearbox is 30% stronger than its competitors.



■ DISCHARGE COVER

Due to its symmetrical design, discharge conveyors and discharge windows can be positioned on both sides, feed discharging process can be made in one or both sides.



■ S355 SHEET METAL QUALITY

The secret of making a long lasting machines is to use the best materials possible. Çelikel® uses resistant to wear and tear S355 sheet metals made of steel improved with many elements in its feed mixers. Thus, your machine will be operating flawlessly for many years to come.

Brassus Micro



Some call it feed mixer we call it BRASSUS. Perfection mechanized and now BRASSUS's 2m³, 3m³, 4m³, 5m³ capacity models are out in stores. Bad news for the competitors. But wait a great news for customers!



LOAD COVER

When it comes to sustainability, there is no one else who can be compared with Çelikel engineers. The load cover is a perfect example for this: This particular cover is designed for small-scaled businesses. It is the same height as the loading bucket but it does not require to have any sort of hydraulic hardware so it is easy to access. You will not need a bucket in Brassus Micro®.

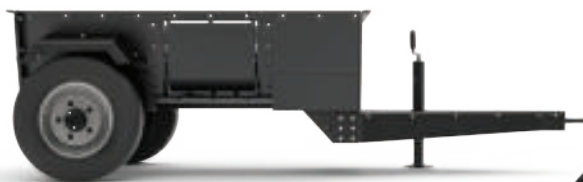

REINFORCED RESERVOIR

Floor plate is made of 8 mm thick S355 sheet metal to make it stronger, rigid and last longer. Metal grid system provides endurance.



RADIAL TYRES

Çelikel® uses innovative tires that provide high resistance to the most challenging road conditions. Due to the high load capacity, strength and resistance to soil compaction, our machines demonstrate flawless performance even in the most difficult conditions.

Chassis Type	2 m ³		3 m ³		4 m ³		5 m ³	
	Trailer type	Stationary type	Trailer type	Stationary	Trailer type	Stationary	Mobile	Stationary
Length-A	3365 mm	2425 mm	3740 mm	2810 mm	4015 mm	3100 mm	4515 mm	3580 mm
Height-B	1690 mm	1820 mm	1865 mm	2010 mm	2065 mm	2195 mm	2150 mm	2195 mm
Width-C	1440 mm	1465 mm	1470 mm	1490 mm	1490 mm	1500 mm	1585 mm	1500 mm
Wheel Trail Width-D	1264 mm	-	1274 mm	-	1272 mm	-	1300 mm	-
Feed Discharge Width-E	1475 mm	-	1540 mm	-	1550 mm	-	1600 mm	-
Auger Core Thickness	8 mm	8 mm	8 mm	8 mm	10 mm	10 mm	10 mm	10 mm
Auger Stripe Thickness	10 mm	10 mm	10 mm	10 mm	12 mm	12 mm	12 mm	12 mm
Side Wall Thickness	4 mm	4 mm	4 mm	4 mm	4 mm	4 mm	4 mm	4 mm
Front Wall Thickness	4 mm	4 mm	4 mm	4 mm	4 mm	4 mm	4 mm	4 mm
Floor Plate Thickness	8 mm	8 mm	8 mm	8 mm	8 mm	8 mm	8 mm	8 mm
Empty Weight	600 kg	850 kg	1065 kg	1015 kg	1250 kg	1160 kg	1450 kg	1350 kg
Loading Capacity	600 kg	600 kg	900 kg	900 kg	1200 kg	1200 kg	1500 kg	1500 kg
The quantity of Knives	26 pcs	26 pcs	36 pcs	36 pcs	52 pcs	52 pcs	68 pcs	68 pcs
Wheel size	165/80-R13-PT311	-	175/65-R14-PT311	-	185/65-R14-PT311	-	10.0/75-15.3-12RF	-
Rim	4.00X13-B4	-	5.50X14-B5	-	5.50X14-B5	-	9.00X15.3	-
Tractor PTO Speed	540 RPM	540 RPM	540 RPM	540 RPM	540 RPM	540 RPM	540 RPM	540 RPM
Tractor PTO Power Requirement	Min 20 hp	Min 20 hp	Min 25 hp	Min 25 hp	Min 30 hp	Min 30 hp	Min 40 hp	Min 40 hp
Electricity Engine Power Requirement	11 Kw - 1500 d/dk	11 Kw - 1500 d/dk	15 Kw - 1500 d/dk	15 Kw - 1500 d/dk	18.5 Kw - 1500 d/dk	18.5 Kw - 1500 d/dk	22 Kw - 1500 d/dk	22 Kw - 1500 d/dk
Mobile Chassis	Standard	-	Standard	-	Standard	-	Standard	-
Stationary Chassis	-	Standard	-	Standard	-	Standard	-	Standard
Weight System	Optional	Optional	Optional	Optional	Optional	Optional	Optional	Optional
Transmission PTO Single Outlet	Standard	Standard	Standard	Standard	Standard	Standard	Standard	Standard
Transmission PTO Double Outlet	Optional	Optional	Optional	Optional	Optional	Optional	Optional	Optional
Transmission + Blackbox PTO Double Outlet	Optional	Standard	Optional	Standard	Optional	Standard	Optional	Standard
Feed Discharge Side Right	Standard	Standard	Standard	Standard	Standard	Standard	Standard	Standard
Feed Discharge Side Left	Optional	Optional	Optional	Optional	Optional	Optional	Optional	Optional
Hydraulic Feed Discharge Cover	Optional	Optional	Optional	Optional	Optional	Optional	Optional	Optional
Mechanical Feed Discharge Cover	Optional	Standard	Optional	Standard	Optional	Standard	Optional	Standard
Feed Discharge Plate	Standard	Standard	Standard	Standard	Standard	Standard	Standard	Standard
Hydraulic Feed Discharge Conveyor	Optional	Optional	Optional	Optional	Optional	Optional	Optional	Optional
Electricity Feed Discharge Conveyor	Optional	Optional	Optional	Optional	Optional	Optional	Optional	Optional
Conveyor Bagging Kit	Optional	Optional	Optional	Optional	Optional	Optional	Optional	Optional
Tractor Independent Hydraulic	Optional	Optional	Optional	Optional	Optional	Optional	Optional	Optional
Tractor Dependant Hydraulic	Optional	Optional	Optional	Optional	Optional	Optional	Optional	Optional
Sliding Hydraulic Control System	Standard	Standard	Standard	Standard	Standard	Standard	Standard	Standard
Wired Hydraulic Control System	Optional	Optional	Optional	Optional	Optional	Optional	Optional	Optional
Back Load Half Cover	Standard	Standard	Standard	Standard	Standard	Standard	Standard	Standard
Back Load Bucket	Optional	Optional	Optional	Optional	Optional	Optional	Optional	Optional
Mechanical Foot Jack	Standard	-	Standard	-	Standard	-	Standard	-

FEED MIXERS

The perfect harmony of design, engineering and style.

Çelikel® has been manufacturing CHARGER® Series in different capacities, ranging from 0,75 m³ to 52 m³ to meet the demands of all the businesses working in livestock industry. CHARGER® Series with vertical auger system comes forth with their chassis design and reservoir capacity. There is not a single thing impossible with more than 250 options and model with CHARGER®! Or were you expecting less of the leader?



PROMISES D

Charger



S DELIVERED

FEED MIXERS

COLLABORATIVE
DESIGN OF TURKISH
AND DUTCH ENGINEERS



While Çelikel® engineers are calculating the size of the mixer from Çelikel, you will instantly realize that it is bigger than the size of its competitors. Remember, not everyone takes inside the reservoir. Let's say you bought a 12m³ feed mixer from Çelikel, you will instantly realize that it is bigger than the size of its competitors. Remember, not everyone is as generous as Çelikel®.

Charger

Feed mixer CHARGER® will execute all sorts of feeding processes without a necessity of a precutting. CHARGER® auger system will make it easy to mix stringy and all kinds of feed components. As a result you will get homogeneous, high

quality mixed feed ration. A homogeneous mix is the best product for nutritional needs of the animals as well as for their feeding behaviour which results in their growth. Charger® promises to increase the wellbeing of your animals.

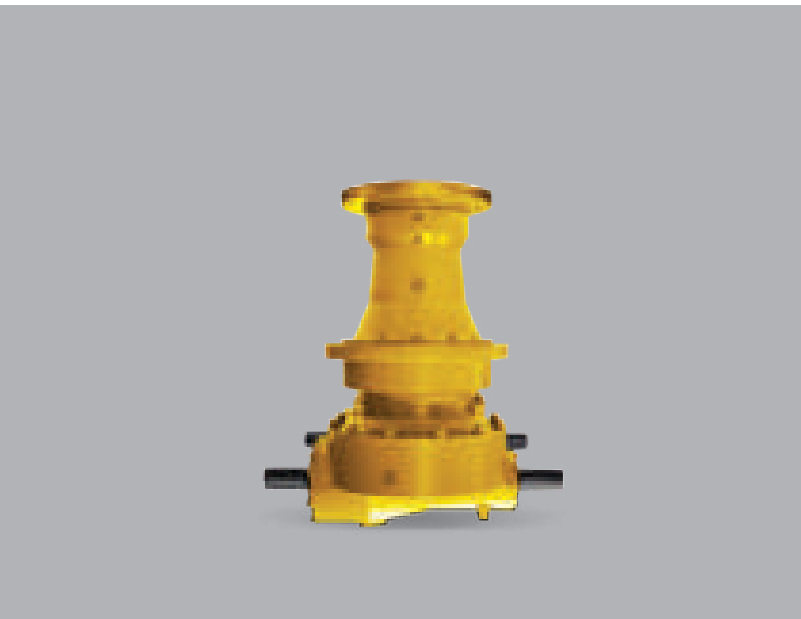

At Celikel we are convinced that the only way to reach perfection is through the harmony of the unique parts. That is why Çelikel® prefers to use Brevini transmission systems for our machines

The augers are specially designed in such a way that they allow you to get the most homogeneous mixture in the shortest time possible. The size of chopping feed is regulated by fixed knives. On request, these knives can be made hydraulically controlled.

FEED MIXERS



■ ELECTRICITY ENGINE

One of the things we needed to provide CHARGER with was to adapt BLACKBOX to vertical mixers, so we did it. Now with BLACKBOX® reducing the fuel can save up to 75% costs.

■ DISCHARGE COVER

Thanks to its symmetrical design and the fact that discharge covers and conveyors can be mounted on both sides, feed discharging process can be done in one go on both sides.

■ WIDE TREAD TYRES

Çelikel® uses innovative tires that provide high resistance to the most challenging road conditions. Due to the high load capacity, strength and resistance to soil compaction, our machines demonstrate flawless performance even in the most difficult conditions.



CHARGER MICRO SERIES DESIGNED ESPECIALLY FOR SMALL AND MIDDLE SCALE BUSINESSES.

Charger Micro Series can be the solution of every business with different capacity options. Micro Series is an expert at mixing coarse and concentrate feed. It offers mixing homogeneous and high quality rations thanks to its capacity based auger systems.



■ FIXED KNIFE

Cutting sizes of the feeds are being done by the fixed knives. Optionally these fixed knives can be manufactured hydraulically controlled.

■ REINFORCED CHASSIS

Charger®'s innovative chassis is one of the many features which makes the machine to stand out. The chassis reinforced with special load cells, long life span, high resistance against twists and sensitive weighing even in rough terrains will add so much to your machine.

■ LOADING BUCKET

Loading bucket whose patent belongs to Çelikel® was designed to make Charger Micro® Series more functional. With forklift like vertical working principle it is safe and fast to put materials in the reservoir.

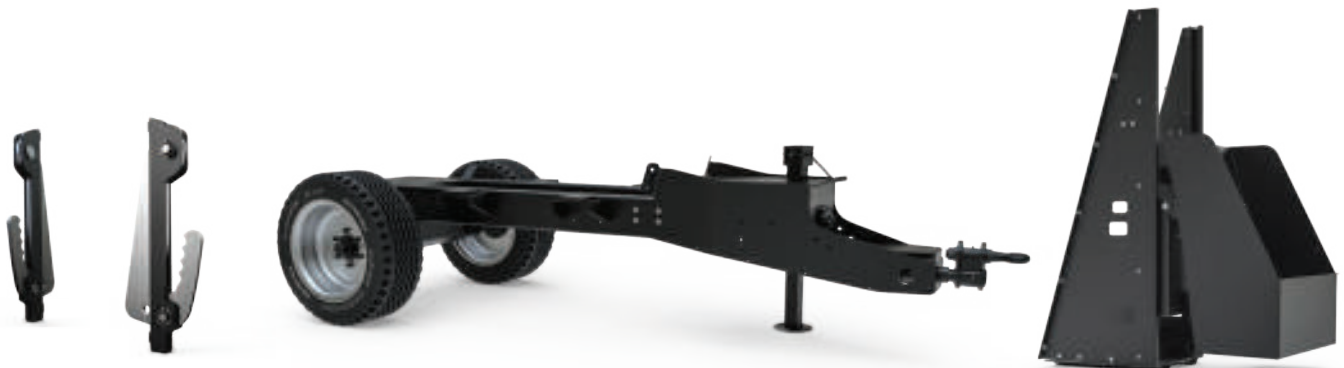

FEED MIXERS



■ LOADING BUCKET

Large capacity loading buckets designed for high capacity Charger® series is developed exclusively for your convenience in reaching and loading without getting exhausted. In every move of Charger®'s loading bucket towards the reservoir you will see flawless material flow into it.

■ INDEPENDENT HYDRAULIC SYSTEM

Independent hydraulic system makes it possible to use the machine's hydraulic components without the requirement of tractor's oil pressure. This detail will save you fuel and time.

■ TWO SHIFT TRANSMISSION

Thanks to the two shift transmission system, according to the capacity of the machine you may choose the appropriate shift and thus make your tractor at ease you will save fuel and more importantly save time.



Charger



■ CONVEYOR

Thanks to its flexible design Charger® V offers you alternative discharge options. One of the discharge options the machine has will be the solution for you depending on your farm's structure and discharging conditions.

■ REINFORCED RESERVOIR

Floor plate is made of 8 mm thick S355 sheet metal to make it last longer, stronger and rigid. In the floor plate metal grid system is used to provide endurance.

■ REINFORCED CHASSIS

The chassis made of S355 steel material attached to the scissors on appropriate points to gain strength, is built on a strong axle. High load capacity chassis is resistant against wear and twist.



FEED MIXERS

If you want to prepare a huge amount of mixed feed ration with spending little energy, you came to the right place. While Charger V Tesla® provides a huge amount of feeding programs in the shortest amount of time, it is generous in production.

With its special weighing system and planning options, it is the most affordable way of preparing rations for big-scale businesses.

Charger V Tesla® is the choice of professionals with capacities ranging from 16 m³ to 55 m³.

Besides having a long life span with the thickness of floor plate and side walls, CHARGER V® series is the most affordable solution to prepare feed mixed rations with its unique auger design.



■ FIXED KNIVES

With Charger®'s fixed knives you may adjust the sizes of feeds. Optionally these fixed knives can be hydraulically controlled.



■ TRANSMISSION

At Çelikel® we are convinced that the only way to reach perfection is through the harmony of the unique parts. That is why Çelikel® prefers to use Brevini transmission systems for our machines



■ SENSITIVE WEIGHING SYSTEM

You will be able to get the desired ration you wish with ease thanks to the sensitive weighing system and thus you may be able to reduce the storage spendings to minimum.

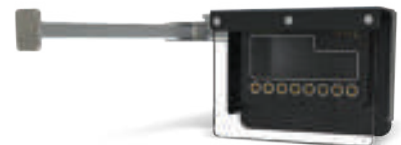

**PRESENTING: THE NEWEST
MEMBER OF CHARGER FAMILY
TESLA®**

The most important point in feed mixing is that the materials inside the machine should be mixed in a homogeneous way. By this way the amount of the feed served to animals from start to finish will be distributed evenly.



■ INVERTOR

In many of the feed mixers if there are cases like power outage or compaction, to be able to start the machine again all the feed inside the machine should be discharged before the restart. Thanks to the invertor system used by Çelikel® such cases can be resolved quite easily.



**■ OVERFLOOD
PREVENTION FRAME**

Overflowing material during feed mixing process can cause financial issues and may prevent the ration from being homogeneous. In Çelikel® machinery overflow prevention frame is given to the user by default.



■ Z CONVEYOR

Designed to conveniently transfer prepared rations to trucks or trailers, the Z conveyor will serve you for years to come, thanks to its low energy consumption and high-strength carrier chains.



CHARGER

	16m ³	18m ³	20m ³	22m ³	16m ³ STATIONARY	18m ³ STATIONARY	20m ³ STATIONARY	22m ³ STATIONARY
Length- (A)	7600 mm	7600 mm	7600 mm	7890 mm	7600 mm	7600 mm	7600 mm	7890 mm
Width- (B)	2225 mm	2225 mm	2225 mm	2225 mm	2225 mm	2225 mm	2225 mm	2225 mm
Height- (C)	2525 mm	2600 mm	2735 mm	2800 mm	2525 mm	2600 mm	2735 mm	2800 mm
Maximum Loaded Weight	11100 Kg	12000 Kg	12700 Kg	13350 Kg	11100 Kg	12000 Kg	12700 Kg	13350 Kg
Empty Weight	6250 Kg	6500 Kg	6690 Kg	6725 Kg	6250 Kg	6500 Kg	6690 Kg	6725 Kg
PTO Speed	540 rpm	540 rpm	540 rpm	540 rpm	540 rpm	540 rpm	540 rpm	540 rpm
WHEEL Size	4 x 215/70/R17.5	4 x 215/70/R17.5	4 x 215/70/R17.5	4 x 215/70/R17.5	4 x 215/70/R17.5	4 x 215/70/R17.5	4 x 215/70/R17.5	4 x 215/70/R17.5
Power Requirement	90 Hp	95 Hp	110 Hp	110 Hp	90 Hp	95 Hp	110 Hp	110 Hp
Weighing System Load Cell Number	3 Pcs	3 Pcs	3 Pcs	3 Pcs	3 Pcs	3 Pcs	3 Pcs	3 Pcs
Auger Knife Number	2 x 6 Pcs	2 x 6 Pcs	2 x 6 Pcs	2 x 6 Pcs	2 x 6 Pcs	2 x 6 Pcs	2 x 6 Pcs	2 x 6 Pcs
Fixed Knife Number	2 Pcs	2 Pcs	2 Pcs	2 Pcs	2 Pcs	2 Pcs	2 Pcs	2 Pcs
Ladder	Optional	Optional	Optional	Optional	Optional	Optional	Optional	Optional
Front Discharge Cover	Standard	Standard	Standard	Standard	Standard	Standard	Standard	Standard
Back Discharge Cover	Optional	Optional	Optional	Optional	Optional	Optional	Optional	Optional
Right Cross Discharge Cover	Optional	Optional	Optional	Optional	Optional	Optional	Optional	Optional
Right Front Cross and Left Front Cross	Optional	Optional	Optional	Optional	Optional	Optional	Optional	Optional
Discharge Covers	Optional	Optional	Optional	Optional	Optional	Optional	Optional	Optional
Bagging Kit	Optional	Optional	Optional	Optional	Optional	Optional	Optional	Optional
Weighing System	Standard	Standard	Standard	Standard	Standard	Standard	Standard	Standard
Loading Bucket System	-	-	-	-	-	-	-	-
Electricity Engine	Optional	Optional	Optional	Optional	Optional	Optional	Optional	Optional
Double Speed (Shift) Reductor	Optional	Optional	Optional	Optional	Optional	Optional	Optional	Optional
Discharge Cover	Hydraulic	Hydraulic	Hydraulic	Hydraulic	Hydraulic	Hydraulic	Hydraulic	Hydraulic
Independent Hydraulic System	Optional	Optional	Optional	Optional	Optional	Optional	Optional	Optional
Conveyor Band	Optional	Optional	Optional	Optional	Optional	Optional	Optional	Optional
Magnet	Optional	Optional	Optional	Optional	Optional	Optional	Optional	Optional
Tractor Mount Type	Tow Type	Tow Type	Tow Type	Tow Type	Tow Type	Tow Type	Tow Type	Tow Type
Axle System with Brakes	Optional	Optional	Optional	Optional	Optional	Optional	Optional	Optional
Warning Light	Optional	Optional	Optional	Optional	Optional	Optional	Optional	Optional
Marker Lamps	Optional	Optional	Optional	Optional	Optional	Optional	Optional	Optional

1m³ FEED = 300 KG (60% OF THE RATION CONTENT IS CALCULATED AS HIGH QUALITY COARSE FODDER.) WEIGHT OF THE MACHINE MAY VARY ACCORDING TO THE OPTIONS CHOSEN. ÇELİKEL TARIM LTD. ŞTİ. KEEPS CHANGING OF TECHNICAL VALUE RIGHTS RESERVED

CHARGER MICRO		0.75m³	2m³V1 (TOW TYPE)	2m³V2 (STATIONARY)	2m³V3 (STATIONARY)	2m³41 (TOW TYPE)	3m³	4m³	5m³	6m³	8m³	10m³	12m³	14m³
Length- (A)		1500 mm	3875 mm	2070 mm	1960 mm	3875 mm	4485 mm	4485 mm	4810 mm	4810 mm	5200 mm	5200 mm	5200 mm	5200 mm
Width- (B)		1500 mm	1680 mm	1920 mm	1450 mm	1800 mm	1850 mm	1850 mm	2115 mm	2115 mm	2300 mm	2300 mm	2300 mm	2300 mm
Height- (C)		1490 mm	1750 mm	1640 mm	1640 mm	1750 mm	2000 mm	2350 mm	2235 mm	2500 mm	2400 mm	2720 mm	3000 mm	3280 mm
Maximum Loaded Weight		605 Kg	1570 Kg	1260 Kg	1170 Kg	1640 Kg	2140 Kg	2520 Kg	3100 Kg	3540 Kg	6785 Kg	7720 Kg	8655 Kg	9590 Kg
Empty Weight		380 Kg	970 Kg	660 Kg	570 Kg	1040 Kg	1240 Kg	1320 Kg	1600 Kg	1740 Kg	4385 Kg	4720 Kg	5055 Kg	5400 Kg
PTO Speed		540 rpm	540 rpm	540 rpm	540 rpm	540 rpm	540 rpm	540 rpm	540 rpm	540 rpm	540 rpm	540 rpm	540 rpm	540 rpm
Wheel Sizes		4 x (M131-121-150)	2 x 185R14C	-	-	2 x 185R14C	2 x 10,0/75-15,3	2 x 10,0/75-15,3	2 x 10,0/75-15,3	2 x 10,0/75-15,3	2 x 12,5/80-15,3	2 x 12,5/80-15,3	2 x 12,5/80-15,3	2 x 12,5/80-15,3
Power Requirements		220V-3kW/4Hp	35Hp	380 V - 7.5kw/10Hp	35Hp	380 V - 7.5 kw/10Hp	40 Hp	40 Hp	50-55 Hp	50-55 Hp	48 Kw / 65 Hp	48 Kw / 65 Hp	59 Kw / 80 Hp	80 Hp
Power Source		Electricity + PTO	PTO	Electricity + PTO	PTO	Electricity + PTO	PTO	PTO	PTO	PTO	PTO	PTO	PTO	PTO
Weighing System Load Cell Number		-	-	-	-	-	3 Pcs	3 Pcs	3 Pcs	3 Pcs	3 Pcs	3 Pcs	3 Pcs	3 Pcs
Auger Knife Number		4 Pcs	5 Pcs	5 Pcs	5 Pcs	5 Pcs	6 Pcs	6 Pcs	7 Pcs	7 Pcs	6 Pcs	6 Pcs	6 Pcs	6 Pcs
Fixed Knife Number		-	2 Pcs	2 Pcs	2 Pcs	2 Pcs	2 Pcs	2 Pcs	2 Pcs	2 Pcs	2 Pcs	2 Pcs	2 Pcs	2 Pcs
Ladder		-	-	-	-	-	-	-	-	-	Optional	Optional	Optional	Optional
Right Side Discharge Cover		Standard	Standard	Standard	Standard	Standard	Standard	Standard	Standard	Standard	Optional	Optional	Optional	Optional
Left Side Discharge Cover		Optional	Optional	Optional	Optional	Optional	Optional	Optional	Optional	Optional	Optional	Optional	Optional	Optional
Front Discharge Cover		-	-	-	-	-	-	-	-	-	Optional	Optional	Optional	Optional
Back Discharge Cover		-	-	-	-	-	-	-	-	-	Optional	Optional	Optional	Optional
Right and Left Side Discharge Cover		-	Optional	Optional	Optional	Optional	Optional	Optional	Optional	Optional	Optional	Optional	Optional	Optional
Right Cross Discharge Cover		-	-	-	-	-	-	-	-	-	Standard	Standard	Standard	Standard
Right Front Cross and Left Front Cross		-	-	-	-	-	-	-	-	-	Optional	Optional	Optional	Optional
Discharge Cover		-	-	-	-	-	-	-	-	-	Optional	Optional	Optional	Optional
Bagging Kit		Optional	Optional	Optional	Optional	Optional	Optional	Optional	Optional	Optional	Optional	Optional	Optional	Optional
Weighing System		-	-	-	-	-	Optional	Optional	Optional	Optional	Optional	Optional	Optional	Optional
Loading Bucket System		-	Optional	-	-	Optional	Optional	Optional	Optional	Optional	Optional	Optional	Optional	Optional
Electric Engine		Standard	-	Standard	-	Standard	Optional	Optional	Optional	Optional	Optional	Optional	Optional	Optional
Discharge Cover		Manual	Hydraulic	Manual	Hydraulic	Hydraulic	Hydraulic	Hydraulic	Hydraulic	Hydraulic	Hydraulic	Hydraulic	Hydraulic	Hydraulic
Independent Hydraulic		-	Optional	-	Optional	Optional	Optional	Optional	Optional	Optional	Optional	Optional	Optional	Optional
Conveyor Band		-	-	-	-	-	Optional	Optional	Optional	Optional	Optional	Optional	Optional	Optional
Magnet		Optional	Optional	Optional	Optional	Optional	Optional	Optional	Optional	Optional	Optional	Optional	Optional	Optional
Tractor Mount Type		3 Aski	Tow Type	3 points linkage system + Stationary type	3 points linkage system + Stationary type	Tow Type	Tow Type	Tow Type	Tow Type	Tow Type	Tow Type	Tow Type	Tow Type	Tow Type
Warning Light		Optional	Optional	Optional	Optional	Optional	Optional	Optional	Optional	Optional	Optional	Optional	Optional	Optional
Marker Lamps		-	-	-	-	-	-	-	-	-	Standard	Standard	Optional	Optional

FORAGE
HARVESTERS

COM

Challenger

In addition to experience, the production of silage machines requires overcoming complex processes in order to increase productivity. Challenger forage harvesters are designed to overcome this difficult processes with an understanding of how important corn and maize silage is to livestock farming.



PETITION IS OVER



FORAGE HARVESTERS

Providing maximum performance with minimum energy consumption is the main characteristic of Çelikel. Challenger® family offers high harvest with low fuel consumption with its light weight and strong transmission system without exhausting your tractor.



360° ROTATING FUNNEL

In all the other equipments, rotation of the funnel is limited only to 90° but in Challenger® it has been increased to 360° thanks to the new clamp system.

One of the most important factors in maize silage is that the maize should be cut and shredded but still remain juicy. Challenger® has the best possible system and equipment to execute this action.



Safety is first! Challenger® series is designed in a way that it does not contact with the ground thus keeping the risk of foreign matters getting into the machine at minimum. But we still keep in mind that such a thing can happen, the security is a big part of work at Çelikel® engineering forage harvester. By doing this, we prevent potential damages from happening.

Challenger



In the flywheel system of the machine there are specially designed sweeping paddles. These paddles are sweeping all the silage inside the machine.

Challenger®'s strong blowing system can blow all the silage to the desired area in the trailer with hydraulically controlled funnel and cover.



Twelve specially designed circular knives of the flywheel are made from high quality materials to minimize the necessity of frequently replacing knives.

FORAGE HARVESTERS



Small and mid scaled businesses' professional solution CHALLENGER® 1 can harvest up to 1500 m² per hour with only 40 hp power requirement. Also due to its hydraulically controlled directed head and funnel system it can direct the silage to the desired area in the trailer with strong blowing system 'Superblow'.



■ BAĞIMSIZ HİDROLİK

In addition to being economical, Çelikel follows the principle of realizing a top-class product in terms of the options included in the package. This is why the Challenger is equipped with a fully independent hydraulic system.



■ KNIFE GRINDING SYSTEM

Çelikel® provides the most efficient and accurate silos grinding method. Challenger provides the most efficient and accurate grinding along with their automatic knife sharpening technology.



■ LEVEL DETECTION TYRE

Safety is an important aspect of production! The level tracking sensor, developed by Çelikel engineers is made specifically to ensure that the machine is not in the contact with the ground so it minimizes the amount of foreign materials which get into the machine.



The Challenger forage harvester doesn't overload your tractor with its lightweight design and powerful transmission, and it also delivers more silage harvesting with less fuel. A single row forage harvester capable of forming one row of maize delivers high levels of productivity thanks to its fully hydraulic control system. The flywheel system consists of

12 chopping knives and 6 guide paddles.

The cutting angle of the knives is specially designed for fast cutting. Composed of 2 gearboxes, 2 shafts and toothed gears, it is the least demanding machine in its class. The forage harvester device makes mowing tall maize easier.



■ FLYWHEEL KNIVES

Specially designed 12 pieces of flywheel knives are strong against wear and made of high quality materials. Therefore the necessity of frequently replacing knives is prevented.

■ INTAKE SYSTEM

Challenger® 1 brings down tall maizes and reduces crop loss to minimum due to row following system. Thanks to its improved flywheel system it makes it easy to reach the highest harvest efficiency possible.

■ SECURITY PIN

All the intake unit is protected by the safety pin. Security pin prevents your machine from getting damaged in case of a soil compaction or foreign materials getting into the machine.

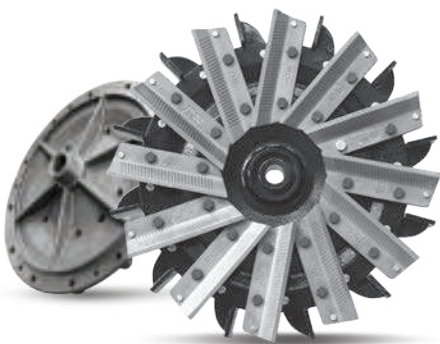

FORAGE HARVESTERS

Challenger 2® Row Independent Forage Harvester is designed to harvest maize and various feed plants which are taller than 1 meter disregarding the row thanks to the wide reaping rollers unit. The machine executes its task even in difficult conditions. It does not exhaust your tractor due to its lightweight. You can be sure that its strong construction will handle pits, bumps and all the other extraordinary conditions.



ROTATING FUNNEL



FUEL SAVING



■ PATENTED FLYWHEEL®

Flywheel system consists of 12 pieces of knives and 12 pieces of sweeping paddles. Thanks to these you will have perfect cutting quality and long range blowing.



■ SUPERBLOW®

ÇELİKEL® created a system that has been added with fully balanced operation of the sweeping paddles and the inlet of the hydraulic funnel, thereby increasing the blowing force. Also we aimed to provide you with the efficiency that you desired by increasing the blowing capacity and the performance of sweeping paddles.



■ 540-750-1000 RPM CHOICES

The independent two-row forage harvester, adaptable to different tractors, offers attachment options to the front, rear and side of the tractor. With transmission RPM options such as 540, 750 and 1000, it enables the most efficient operation.

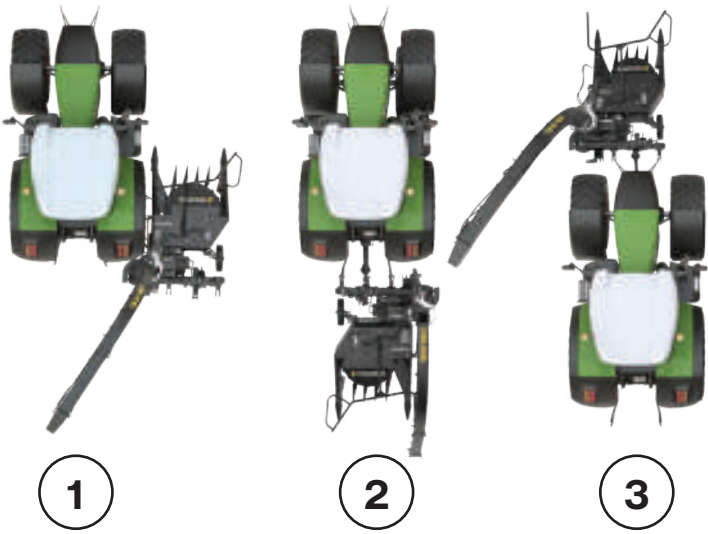

THREE DIFFERENT WAYS TO WORK

Challenger 2® offers alternative harvest methods alongside with regular ones. This machine has the ability to be mounted in the front, on the sides and at the back of the tractor to harvest. Foldable chassis: It is easy, practical and functional to fold and unfold. In addition, the fixing of the machine in the desired position is carried out only with the help of the cover, which prevents loss of time and labor costs.

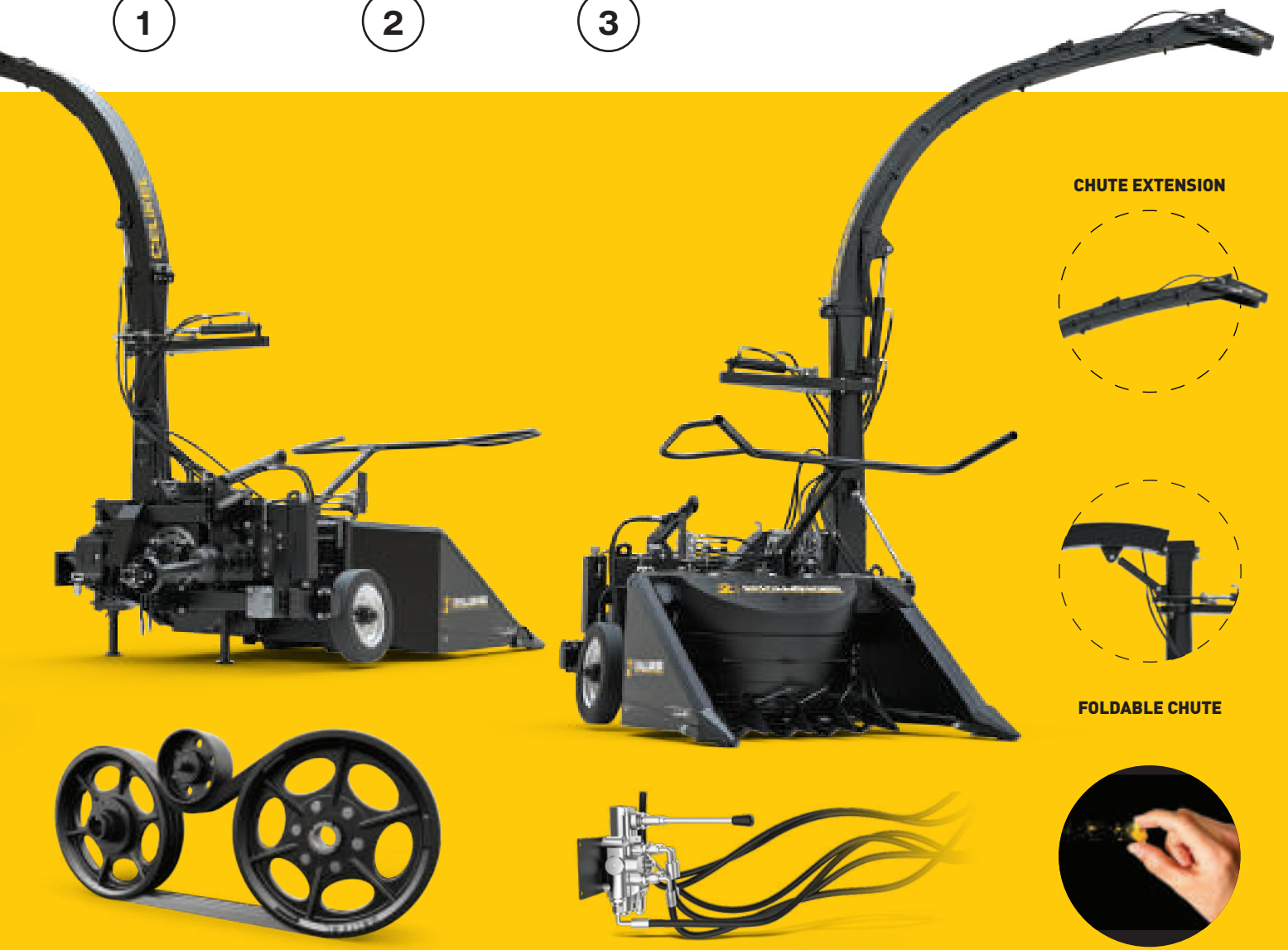

CHUTE EXTENSION



FOLDABLE CHUTE



■ PATENTED BELT STRETCH SYSTEM®

Gears in the machine are supposed to take the power they have received from the PTO to make sure the machine is running smoothly. Power transmission through the gears are being done by hoops and belts and thus helping the user with spare parts, maintenance and repair.

■ INDEPENDENT HYDRAULIC SYSTEM

In addition to being economical, Celikel follows the principle of realizing a top-class product in terms of the options included in the package. Therefore, Challenger® is equipped with completely independent hydraulic system.

■ CORN GRAIN BREAKING

As Çelikel® we care about your animals' daily nutrition and energy needs. To increase the efficiency of maize silages you make we added corn grain breaking feature to Challenger 2®.

FORAGE HARVESTERS

It is the most desirable machine of the industry.

Some customers want it because of its appearance. Some want it because of what others say about it. Some other people want it for its performance. Other clients want it for prestige. Some customers want it because selling it second hand is a bargain. Some does not need an excuse, they just want it:

The most successful machine of agriculture industry in Turkey! CHALLENGER®!

Presenting you the new partner in your business: CHALLENGER 3®. Everything you ever wanted is in this machine!

CHUTE EXTENSION



FOLDABLE CHUTE

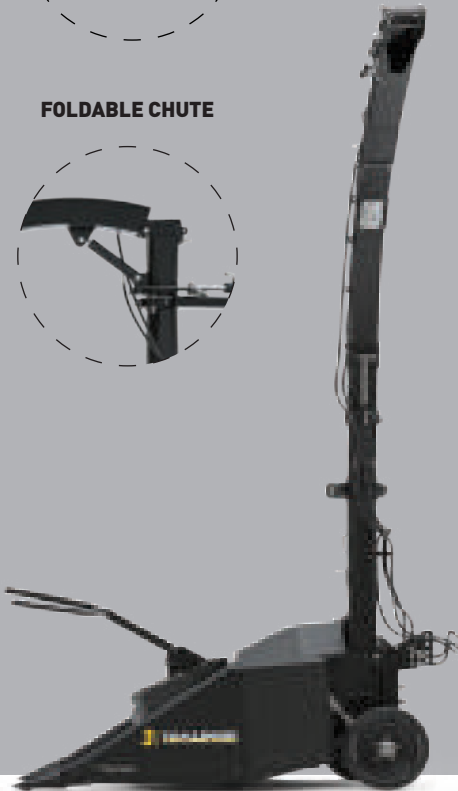

■ SUPERBLOW®

Due to its 360-degree rotating hydraulic funnel and controllable cover, it can load the silage into specific parts of the trailer due to its powerful blowing system.

■ PATENTED FLYWHEEL®

The flywheel system consists of 12 excellent cutting knives and 12 sweeping paddles. This adds a powerful blowing and perfect chopping quality.

■ 540-1000 Rpm CHOICES

Challenger 3® has 3 different PTO options offered in its default hardware. As Standard, it can be used both in the front and at the back of the tractor. This harvester can run at 540rpm or 1000rpm without any modifications.



TWO DIFFERENT WORKING DIRECTION

Challenger 3® offers users different harvest alternatives. This versatile machine is able to harvest in the front of the machine and at the back of the machine.



ROTATING FUNNEL



110 HP



FUEL SAVING

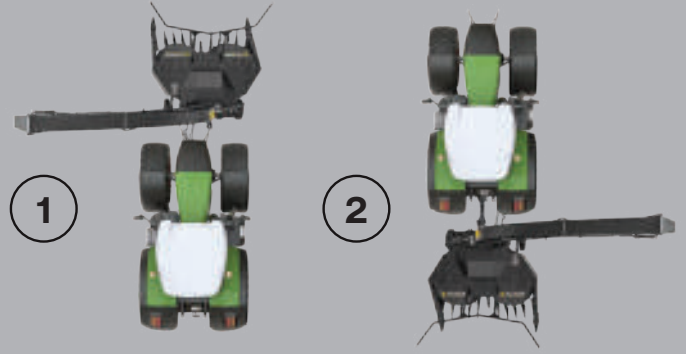

■ MAXIMUM SECURITY

In Challenger 3®, power transmission system combined by belt and gearboxes tprotects the machine from any unwanted conditions.



■ LOW POWER REQUIREMENT

Presenting you the one and only forage harvester which can be run by only 110HP. Once again Çelikel® proves that big machines can also be worked with low power requirements by its engineering abilities.



■ CORN GRAIN BREAKING

As Çelikel® we care about your animals' daily nutrition and energy needs. To increase the efficiency of maize silages you make we added corn grain breaking feature to Challenger 3®.



FORAGE HARVESTERS



Çelikel engineers designed Challenger® 4 Silage Machine inspired by one of the most durable and quick animals: Scorpion. For 60 years almost every year we design at least one new machine. And this year we present to you: The Challenger® 4! It is the aristocrat of forage harvesters. We produced the machine of tomorrow today by the power of our previous experiences!

The Challenger 4 steel parts reflect modern style and compelling aesthetics. You will understand what we are talking about when you see CHALLENGER 4. You may even think that we have not told everything!



■ LOW POWER REQUIREMENT

Presenting you the one and only forage harvester which can be run by only 110HP. Once again Çelikel® proves that big machines can also work with low power requirements due to engineering design.

■ MULTISPEED TRANSMISSION

The unique Challenger® 4 gearbox can adjust to the front based on corn yield, operating in 4 forward and 4 reverse speeds. With the Challenger® 4, the efficient harvesting is completely under your control.

■ INDEPENDENT HARVESTING ROLLERS

Çelikel®, Challenger® Serisi'nde balansı alınmış şasi ve biçim tamburları kullanılır. Balansı alınmış ve keskin bıçaklarla donatılmış bağımsız biçim tamburları ile mahsülü en zor koşullar altında bile zorlanmadan hasat edebileceksiniz.

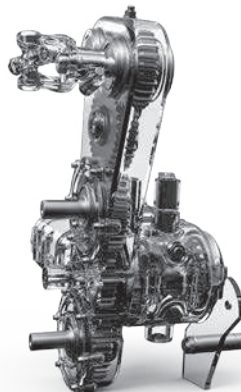

4 / CHALLENGER
COMPETITION IS OVER



FOLDABLE CHUTE

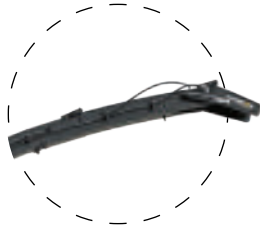

CHUTE EXTENSION



With the fastest Silage Machine in the world Challenger® 4, keep your time for yourself.

The new quadruple row forage harvester which can run only with 150 HP tractor hit the field 150. Your move.

First things Challenger® 4 will make you feel: Consistency, translation of modern style into steel and irresistible appeal of aesthetics. We produced a unique machine for you combining such aesthetics with low power requirements. Challenger® 4 is waiting for you with 1000 rpm transmission and its compatibility with various tractors.



■ ROLL BACK

When there is a soil compaction you will be able to easily solve the problem by simply running the machine backwards and rolling materials back out.

■ ADVANCED SECURITY SYSTEM

With advanced security system while harvesting if there is a soil compaction and blockage it may damage the reaping system of the machine, clutching system inside the gearboxes will come into action while the plant is just at the entrance of the machine and prevent potential overloading in other transmission parts.

■ ADJUSTING CHOPPING SIZE WITH TRANSMISSION

Thanks to Challenger® 4's multispeed transmission, you can adjust the cutting size by speeding the machine up and down.



FORAGE HARVESTERS

When you see Calabria® your heart will start racing, your pupils will get larger and you will say without realizing “my new machine must be Calabria®”. One of the most desirable machines in the history of forage harvesters, Calabria® is waiting for you with the base made of raw steel.

Everything started by a farmer wanting the perfect forage harvester from Çelikel®. With the shortest chopping height and the best blowing ability, Calabria® is built with S355 steel materials.



■ PATENTED FLYWHEEL SYSTEM®

Calabria® has reached the ability to chop even shorter compared to its competitors with its increased width of sweeping paddles and patented knife system.

■ PATENTED ROTOR SYSTEM®

While designing rotor system in Calabria® we have gone beyond the usual. It cuts the forage with minimum loss thanks to its specially designed knives.

■ AUTOMATIC KNIFE GRINDING

The die-cast body is vibration-free with perfect paddles sharpening. The knife sharpening mechanism allows it to be adjusted parallel to the circular knife thanks to a special adjustment system. Thus, the entire sharp surface of the paddles is sharpened.

Obviously, everybody looks at you while you operate this machine. Obviously, they get a little jealous. This is actually predictable. After all, you have the machine of their dreams!



■ REAPING WITHERED FORAGE

Withered forage is healthy and important source of feed for your animals. Calabria® can reap the withered forage thanks to its ability to chop extra short. It can cut the withered forage easier than its competitors.

■ ADJUSTABLE REAPING HEIGHT

You can adjust the height of the machine from the ground without getting off the tractor. With Calabria® you can take the forage just a little higher than the ground level, collect it then transfer it to the flywheel.

■ SENSITIVE CHOPPING SIZE

We used specially designed and developed rotor and flywheel knives in Calabria® with the results from flow analyses. Now it is easier to set the cutting size of the forage in the desired measures.

	SINGLE ROW MAIZE CHOPPER	2 ROWS MAIZE CHOPPER	3 ROWS MAIZE CHOPPER	4 ROWS MAIZE CHOPPER
WORKING WIDTH	70 cm	125 cm	210 cm	300 cm
WORKING CAPACITY *	1000 - 1500 m ² /hr	4000 - 4500 m ² /hr		8000 - 10000 m ² / hr
MINIMUM POWER REQUIREMENT**	28 kW (40 hp)	56 kW (75 hp)	80 kW (110 hp)	100 kW (135 hp)
PTO WORKING REV	540 RPM	540 / 750 RPM (Optional)	540 / 1000 RPM	1000 RPM
WORKING POSITION	RIGHT SIDE	FRONT (Optional) / RIGHT SIDE / BACK	FRONT / BARK	BACK (Standard), FRONT (Optional)
SWEEPING PADDLE NUMBER	6	12	12	12
CHOPPING KNIFE NUMBER	12	12	12	12
SHREDDING KNIFE NUMBER	12	12	12	12
FIXED KNIFE NUMBER	1	1	1	3
SHREDDING SIZE***	3 - 10 mm	ADJUSTABLE (3 - 10 mm)	ADJUSTABLE (3 - 10 mm)	ADJUSTABLE (4,3 - 33 mm)
WHEEL SIZES	16X6,5-8	165x70x13	165x70x13	21 x 8 - 9 NHS
WHEEL NUMBER	1	1	2	2
THREE POINT LINKAGE	CATEGORY II	CATEGORY II - III	CATEGORY II - III	CATEGORY II - III
LENGTH (WORK POSITION)	2380 mm	2679 mm (Side position), 2750 mm (Back position)	2600 mm	2920 mm
HEIGHT (WORK POSITION)	3175 mm	4130 mm	4165 mm	4375 mm
HEIGHT (ROAD POSITION)	2122 mm	2460 mm	2475 mm	2703 mm
WIDTH (WORK POSITION)	2355 mm	4190 mm	4115 mm	3055 mm
WIDTH (ROAD POSITION)	2355 mm	1985 mm	2420 mm	3055 mm
WEIGHT	600 kg	1350 kg	1520 kg	2350 kg
INDEPENDENT HYDRAULIC	-	Standard		Standard
HYDRAULIC CONTROL PLACEMENT	-	NEXT TO OPERATOR (INSIDE THE CABIN)		
CIRCULAR KNIFE NUMBER	-	6	6	
CORN GRAIN BREAKING AND SHREDDING SYSTEM	-	ON TOP OF SPECIAL DESIGN CHOPPING KNIFE, - SHREDDING KNIVES, - OPTIONAL INSIDE RESERVOIR GGG60, - CAST BREAKERS	ON TOP OF SPECIAL DESIGN CHOPPING KNIFE, - SHREDDING KNIVES, - OPTIONAL INSIDE RESERVOIR GGG60, - CAST BREAKERS	
SECURITY SYSTEM	-	POWER TRANSMISSION BELT	POWER TRANSMISSION BELT	
MACHINE MOVEMENT TRANSMISSION	-	GEARBOX AND FLEXIBLE TRANSMISSION COMBINATION	GEARBOX AND FLEXIBLE TRANSMISSION COMBINATION	
HYDRAULIC MIDDLE LEVER	-	Standard	Standard	
TEMPORARY RUNNING REVERSE				Standard

POWER REQUIREMENT (MIN – MAX)	45 – 60 kW	60 – 80 kW	80 – 100 kW
WORKING WIDTH	1500 mm	1800	2100
ROTOR KNIFE NUMBER	36 pcs	48 pcs	56 pcs
CHOPPING KNIFE NUMBER	10 pcs	10 pcs	10 pcs
SWEEPING PADDLE NUMBER	10 pcs	10 pcs	10 pcs
WHEEL SIZES	165X70XR13	165X70XR13	165X70XR13
ROTOR REV NUMBER	2250 RPM	2250 RPM	2250 RPM
CHOPPING KNIFE REV NUMBER	1620 RPM	1620 RPM	1620 RPM
WEIGHT	925 KG	975 KG	1045 KG
PTO REV NUMBER	540 RPM	540 RPM	540 RPM
WORK CAPACITY *	20 ton / hr	25 ton / hr	30 ton / hr
WIDTH (WORK POSITION)	2535 mm	2835 mm	3135 mm
HEIGHT (WORK POSITION)	3700 mm	3700 mm	3700 mm
LENGHT (WORK POSITION)	2400 mm	2400 mm	2400 mm
WIDTH (ROAD POSITION)	2540 mm	2840 mm	3140 mm
HEIGHT (ROAD POSITION)	2355 mm	2355 mm	2355 mm
LENGTH (ROAD POSITION)	3170 mm	3170 mm	3170 mm
CHOPPING SIZE (ADJUSTABLE)	20 – 70 mm	20 – 70 mm	20 – 70 mm
REAPING HEIGHT (ADJUSTABLE)	50-150 mm	50-150 mm	50-150 mm

CHALLENGER

AVERAGE SILAGE YIELD IS CONSIDERED AS 7500. IT MAY VARY DEPENDING ON THE OPERATOR EXPERIENCE AND FIELD CONDITIONS.
 AVERAGE SILAGE YIELD IS CONSIDERED AS 7500. IT MAY VARY DEPENDING ON THE OPERATOR EXPERIENCE AND FIELD CONDITIONS.
 ARE TRACTOR PTO VALUES.

*** ARE AVERAGE VALUES. IT MAY VARY DEPENDING ON THE HUMIDITY AND THE TYPE OF THE PRODUCT.

TECHNICAL FEATURE VALUES ARE VALID AFTER THE DATE OF RELEASE. ÇELİKEL TARIM LTD. ŞTİ. KEEPS CHANGING OF TECHNICAL VALUE RIGHTS RESERVED WITHOUT THE NECESSITY OF A PUBLIC DECLARATION.
 TECHNICAL FEATURE VALUES ARE VALID AFTER THE DATE OF RELEASE. ÇELİKEL TARIM LTD. ŞTİ. KEEPS CHANGING OF TECHNICAL VALUE RIGHTS RESERVED WITHOUT THE NECESSITY OF A PUBLIC DECLARATION.

PACKING

MACHINES



BUILT TO
LAST *Perpetual*



The packing master for small and midium-sized enterprises.

While developing the Perpetual®, we chose to use a fully automatic, low-cost, economical and semi-automatic machine for users. The more you win, the more you earns!

PACKING

MACHINES

You can pack with different weights from 25 kg to 50 kg. Thanks to the touch control panel, you can view all functions on one screen, access information about product weight and quantity and act if it is necessary.



PERPETUAL® packaging concept begins with the transfer of materials prepared by a mixer onto a band. Materials delivered to the dispensing system via the band are transferred from here into bags. After the air is removed from the package, the movement of material in the system ends by pressing and closing the top of the bag. Since the pressing process is the main factor in the life of the packaged product, the pressing process will be ideal thanks to the four powerful pneumatic piston.



Perpetual

Maize silage, beet pulp, vetch silage, coarse fodder, pellet feed, potato pulp, fruit pulp, olive pulp, grape pulp, barley, wheat, manure and industrial waste are in the list of things which can be packed with this machine.

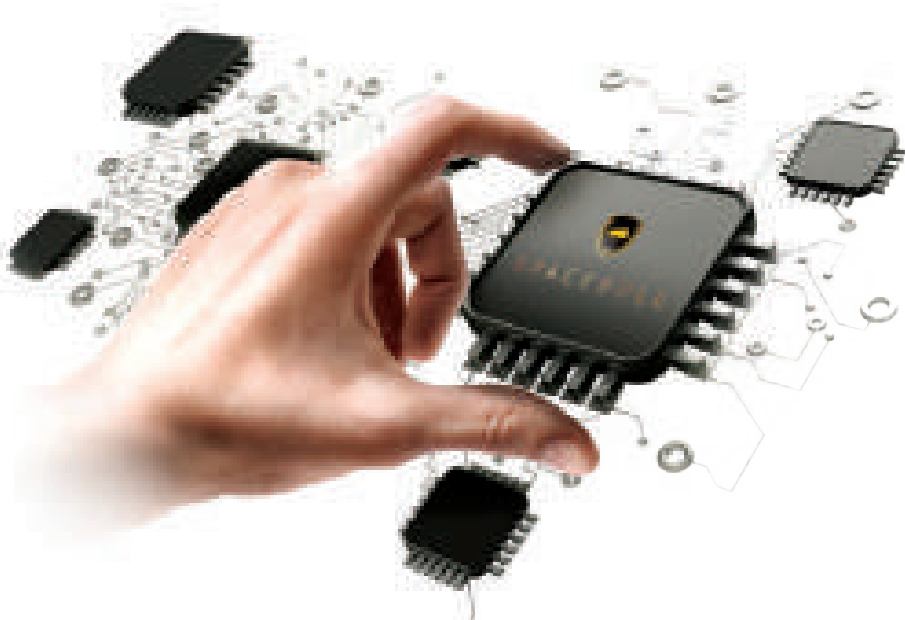

It is quite easy to operate the machine with SPACEBULL PLC control panel and extensive interface. You can control all the functions of the machine from a touch operated monitor and you can reach the information such as the weight, number and etc. of the product.

PACKING

MACHINES

Perpetual GO is the packaging master. With the GO series, bags from 20kg to 60kg can be packed and the touch-screen control panel allows you to view all functions on one screen. This way, you can easily access information such as weight and product number. The Perpetual GO is designed to make things easier for you with its ability to pack nine tons per hour.

With Perpetual GO® you can easily pack materials such as maize silage, beet pulp, vetch silage, coarse fodder, pellet feed, potato pulp, fruit pulp, olive pulp, grape pulp, barley, wheat, manure and industrial waste.



■ STRONG CHASSIS FRAME

Considering PERPETUAL® operating conditions, we have presented a chassis design that will not let the user down.

■ REMOTE CONTROL

o be able to help with potential problems PERPETUAL®'s SPACE-BULL software has an integrated remote connection feature. Thanks to this system, if a problem occurs and user can not fix it Çelikel® technical assistance crew can remotely connect and rectify this issue.

■ ADJUSTABLE PACKET WEIGHT

Thanks to the PLC, which allows the digital display and scale system on the machine work together, you can easily choose the packaging capacity by selecting one of the options from 20 kg to 60 kg on the digital screen. You will get perfect packages with a maximum error of 0.2%.

■ AUTOMATIC CONVEYOR

PERPETUAL's intake unit is controlled by SPACEBULL automation system and the system automatically executes the carrying of materials which will be packed.

■ MIXING BUNKER

When there is a demand for more than one material to be packed PERPETUAL's mixing bunker mixes these materials homogeneously to make sure you get a Standard ration in each packet.

■ MOBILITY & GO

Thanks to its mobile structure it may save you transportation costs and you can easily move your machine to a place with electricity and start working easily.

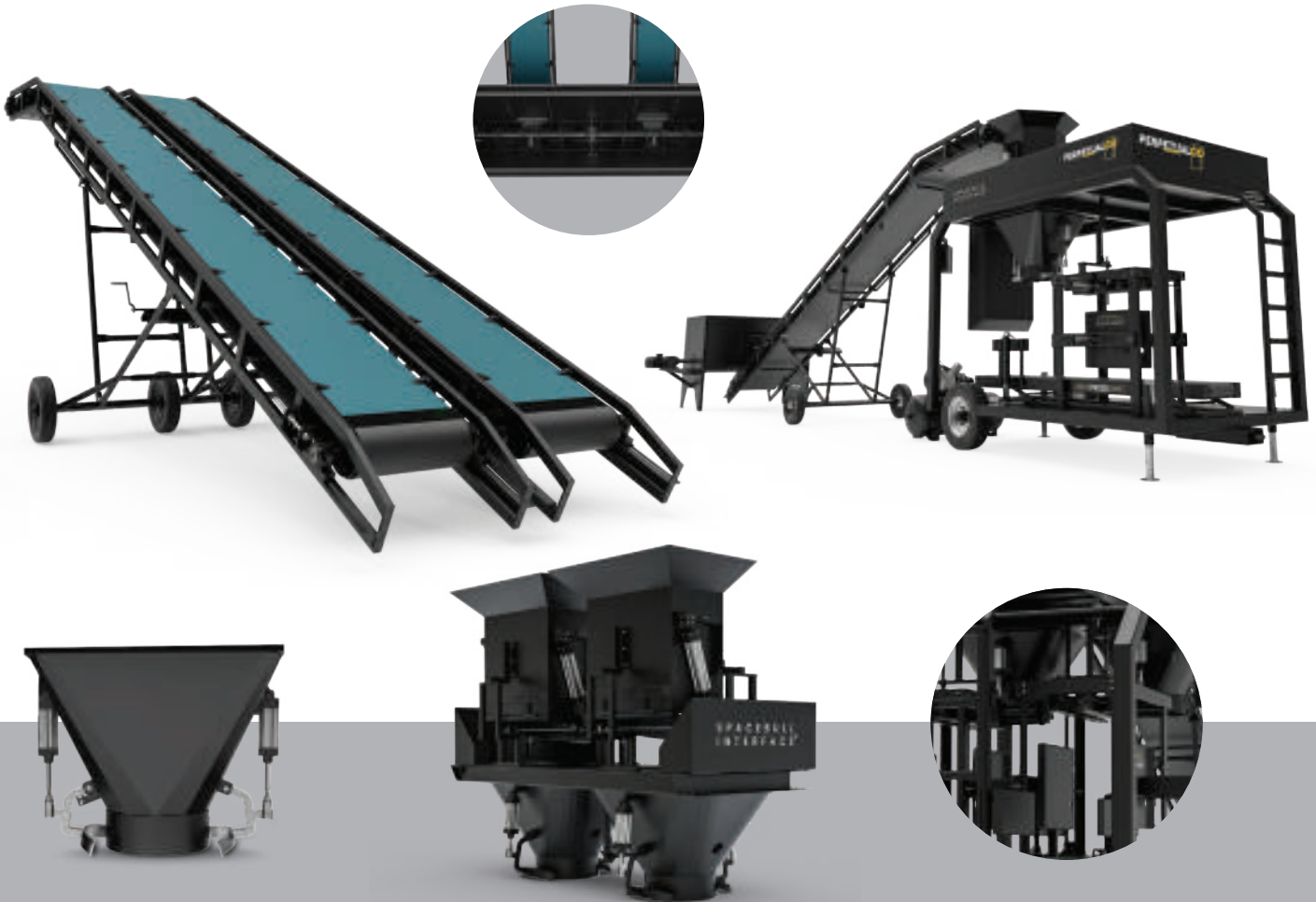

■ DOSING SYSTEM

To be able to provide the sensitivity in dosing. Perpetual GO® Series's dosing system has programmable speed setting. You can achieve the desired sensitivity easily by adjusting general and precise speed settings for different weights.

■ DOUBLE STATION

Two different station independent from one another. Two independent packing machine in one body, each can work with high performance.

■ PRESS SYSTEM

Packets filled with materials are brought to vacuum station, after the air inside the packets is vacuumed the packets are pressed and sealed. The difference in Perpetual® packing system from its competitors is that thanks to its adjustable band height all the packets are packed rigidly and consistently.

PACKING

MACHINES

There is no need to worry about packing with Perpetual Ultimate®. You can do packing from 25 kg to 50kg with Ultimate® model. Thanks to the touch operated control panel you can observe all the functions from single monitor and reach informations such as weight and number of the product. Perpetual Ultimate® is faster than ever with a packing capacity of 10-15 tons an hour.

With Perpetual Ultimate® you can easily pack materials such as maize silage, beet pulp, vetch silage, coarse fodder, pellet feed, potato pulp, fruit pulp, olive pulp, grape pulp, barley, wheat, manure and industrial waste



■ TIPPER INSTALLED BUNKER

Thanks to high power of intake conveyor engines, you can load high weight loading to Perpetual®.

■ DOUBLE STATIONS AND CAPACITY INCREASE

Two different station independent from one another. Two independent packing machine in one body, each can work with high performance.



■ REMOTE CONTROL

To be able to help with potential problems PERPETUAL®'s SPACEBULL software has an integrated a remote connection feature. Thanks to this system, if a problem occurs and the user can not fix it Çelikel® technical assistance crew can remotely connect and rectify.

■ **MOBILE STRUCTURE**

You can cut spendings thanks to its mobile structure and move your machine and start working in a place where there is electricity.

Mobile single and double stationed model is equipped with Standard hardware with low maintenance cost, easy to find spare parts and a long lifespan. Besides single and double stations there are embedded vertical carrier and bunker reservoir as system component.

Thanks to chained Z conveyor and chained bunker conveyor, highly loaded trailers and trucks can feed the machine. Vertical carrier is made of Z conveyor's movement speed, an adjustable pair of chains and brace plates between chains.



■ **DOSING SYSTEM**

All parts of the machine in contact with the packaged product are chrome plated. This function has been added to the machine in case of damage to machine parts during the packaging process.



■ **ADJUSTABLE PACKET WEIGHT**

Perpetual® offers adjustable packet weight capacity with the press system. You may set a weight option between 25 kg up to 50 kg on the digital monitor on the machine. You will get flawless packets with a possibility of a error only 0.2%.



■ **BUNKER MIXING AUGER**

With PERPETUAL® our aim was to provide flawless packets. There has always been the possibility of materials getting stuck together and making it to the packets yielding bad results in consistent packing. Until now! Thanks to marvellously designed bunker mixing auger, we prevent this kind of error from happening.

PACKING

MACHINES

While developing the Perpetual®, we chose to use a fully automatic, low-cost, economical and semi-automatic machine for users. The more you win, the more you earns!



PERPETUAL <small>UNITED STATES</small>	PERPETUAL STD		PERPETUAL STD II		PERPETUAL GO		PERPETUAL GO II		PERPETUAL ULTIMATE	PERPETUAL ULTIMATE II
	MACHINE	SYSTEM	3500 mm	SYSTEM	MACHINE	SYSTEM	MACHINE	SYSTEM	MACHINE	MACHINE
Chassis Option	SYSTEM	4000 mm	3150 mm	10500 mm	4440 mm	3370 mm	4700 mm	10300 mm	7800 mm	MACHINE
Length-A	SYSTEM	4000 mm	3150 mm	10500 mm	4440 mm	3370 mm	4700 mm	10300 mm	7800 mm	9000 mm
Height-B	3500 mm	3400 mm	3400 mm	3400 mm	3470 mm	3720 mm	3440 mm	3690 mm	2800 mm	2890 mm
Width-C	4000 mm	8500 mm	3400 mm	3400 mm	1650 mm	8900 mm	2420 mm	2950 mm	2200 mm	2680 mm
Wheel Trail Width -D	3150 mm				1450 mm		2130 mm		1920mm	2120 mm
Packing Capacity	180-240 pack/hour		360-480 pack/hour	180-240 pack/hour	180-240 pack/hour	360-480 pack/hour	160-220 pack/hour	10 ton(s)/hour	10 ton(s)/hour	
Maize Silage	6 ton(s)/hour		12 ton(s)/hour	6 ton(s)/hour	6 ton(s)/hour	12 ton(s)/hour	5 ton(s)/hour	15 ton(s)/hour		
Beet Pulp	9 ton(s)/hour		18 ton(s)/hour	9 ton(s)/hour	9 ton(s)/hour	18 ton(s)/hour	7.5 ton(s)/hour	20-60 kg		
Weight	20-60 kg		20-60 kg	20-60 kg	20-60 kg	20-60 kg	20-60 kg	200 - 250 gr		
Grammage Tolerance	200 - 250 gr		200 - 250 gr	200 - 250 gr	200 - 250 gr	200 - 250 gr	200 - 250 gr	4710 kg		
Empty Weight	1100 kg		2300 kg	1800 kg	1800 kg	2450 kg	3150 kg	12 KW		
Power Requirement (KW)	9 KW		18 KW	9 KW	9 KW	18 KW	9 KW	24 A		
Power Requirement (A)	18 A		36 A	18 A	18 A	36 A	18 A	3 PHASE		
Power	3 PHASE		3 PHASE	3 PHASE	3 PHASE	3 PHASE	3 PHASE	1,5 KW		
Vacuum Power	0,75 KW		1,5 KW	0,75 KW	0,75 KW	1,5 KW	0,75 KW	12,5 / 80 15,3		
Wheel Sizes	n/a		n/a	185 R 14C	185 R 14C	225 / 70 R 15C	10.0/75 15,3	500 L		
Compressor Capacity	300 L		500 L	300 L	300 L	500 L	300 L	6-8 BAR		
Air Pressure Requirement	6-8 BAR		6-8 BAR	6-8 BAR	6-8 BAR	6-8 BAR	6-8 BAR	Hot Sealing		
Packet Sealing	Hot Sealing		Hot Sealing	Hot Sealing	Hot Sealing	Hot Sealing	Hot Sealing	6 pcs		
Load Cell Number	3 pcs		6 pcs	3 pcs	3 pcs	6 pcs	3 pcs	2 pcs		
Station Number	1 pcs		2 pcs	1 pcs	1 pcs	2 pcs	1 pcs	Standard		
Dosing Reservoir	Standard		Standard	Standard	Standard	Standard	Standard	Bunker		
Intake System	Mixer + Conveyor		Mixer + Conveyor	Mixer	Mixer	Mixer	Bunker	Mixer		
Option -1-	n/a		n/a	Dosing in Pack	Dosing in Pack	Dosing in Pack	Mixer	Dosing Reservoir		
Option -2-	n/a		n/a	n/a	n/a	n/a	Dosing Reservoir	Standard		
Ladder	Standard		Standard	Standard	Standard	Standard	Standard	Standard		

WEIGHT VALUES IN THE TABLE ARE FOR BASE MACHINE. MACHINE WEIGHTS MAY VARY ACCORDING TO THE OPTIONS.

ÇELİKEL TARIM LTD. ŞTİ. KEEPS CHANGING OF TECHNICAL VALUE RIGHTS RESERVED.

MANURE MANAGEMENT

MACHINES



ROUGHER TOUGHER

Organic manure's contribution is an undeniable fact in the field. Çelikel®'s manure management machines are equipped with special hardwares in order to maximize the benefit from the manure.

Animal fertilizers are valuable sources that –if used correctly- can replace chemical fertilizers. But if animal fertilizers are not managed very carefully they become a source of smell and emission, they lead to loss of nutrition and a threat to ground waters. In order to execute the manure management successfully, Çelikel® designed Crafter®, Cruiser® and Scud®.



Crafter & Cruiser

RCRAFTER

MANURE MANAGEMENT

MACHINES

In today's highly competitive market, you can't afford to skimp on quality. With our products, you can always stay ahead of the curve. CRAFTER® is more than a machine, we enriched it with special equipments to maximize the benefit businesses' can make from the organic manure.



Crafter

PALLET SYSTEM

Crafter® has foldable pallets which keep on working without any problem in case of a collision with materials that can harm the mechanism. In addition to this, after stopping it has a axle system which slows down safely to increase the lifespan of the machine.



GUILLOTINE BACK COVER

Crafter® presents the opportunity to adjust manure spreading level from tractor via hydraulic guillotine cover system. Back cover is equipped with strong hydraulic cylinders to be able to move vertically. And it can be opened and closed without getting affected by the manure inside the trailer.



Cruiser

If your heart does not race when you look at CRUISER®, call a doctor! Most definitely your heart stopped beating!

More pressure with each gallon, more progress with each decare! Presenting the new machine of Çelikel®, CRUISER®! You are no longer alone with your battle for productivity!

Çelikel® focuses on finding solution for any possible problems that our clients might have. One of the major problems of the businesses' animal manure was solved with Scud®. Due to carbide plated auger system and specially designed strainer Scud® makes it easy to separate manure. With manure acid-resisting Scud® you are in charge of manure management.



Cruiser®'s pump is reliable and durable so it guaranties a long lifespan while doing all these works. It is equipped with a warning system with flashing lights to prevent potential work accidents. The warning system is placed on top of the CRUISER® so it is clearly visible at night.

Using organic manure in the field increases the efficiency. You can see how Cruiser® is serious in performance via pressure and vaccum indicators which will make it easier to use liquid fertilizers in the field! Cruiser®'s perfect pump intake and pressure power makes it easy to fill the tank. After filling the tank you may easily fertilize the field.



MANURE MANAGEMENT

MACHINES

An immense contribution which organic manure brings is beyond any doubts. Çelikel®'s manure management machines are equipped with special hardwares in order to maximize the benefit from the manure. Spreading width and homogeneity which Crafter® provides makes it a masterpiece of Çelikel® engineering. It can work up to a width of 25 meters.



■ STRONG CHASSIS

Crafter® is designed to with a strong chassis structure to keep the user safety a top priority even on the most challenging road and field conditions.

■ HYDRAULIC CONTROL

Crafter® is equipped with hydraulic control interface to increase usability. In the front of Crafter®. You can operate the hydraulic jack with three hydraulic control levers located on the front of the Crafter® and apply fertilizer after lifting the rear hydraulic gate.

■ WIDE TYRE

Çelikel prefers the best partners to keep the machines working flawlessly even in the most difficult conditions. Çelikel uses innovative tires that provide high resistance to the most challenging terrain conditions, thanks to the high load capacity, strength and anti-soil compaction, thus achieving flawless results.



CHAIN CLEANING SYSTEM

There is a chain cleaning rubber in manure spreading machines to prevent manure from damaging machine's parts. Clean chains will prevent manure from getting out of manure reservoir and machine's parts will not be under corrosion threat.

STRONG AXLE STRUCTURE

The shaft with which we connect the cardan shaft used between the tractor and the machine is linked to a solid shaft structure. This shaft is designed to work flawlessly even under difficult working conditions and thus will assure you.

HYDRAULIC BREAK SYSTEM

There is a hydraulic break system on the axle to provide safe usage of Crafter. Simply by connecting hydraulic break hose to the tractor the system will be connected to tractor and whenever you need it, you can slow down the machine and the tractor due to the hydraulic break system.



CHAIN SYSTEM

There is a chain cleaning rubber in manure spreading machines to prevent manure from damaging machine's parts. Clean chains will prevent manure from getting out of manure reservoir and machine's parts will not be under corrosion threat.

SCISSOR AXLE

The Crafter® uses a scissor shaft, which allows flexible operation and minimum pressure on the tractor. The scissor shaft of the Crafter® type is designed so that you can easily use the machine in dented, mounded fields.

TRANSMISSIONS

The gearboxes used in the Crafter® are designed to perform flawlessly due to clear manufacturing process. The combination with a triple reduction gear for the rotation of the augers is made with especially reinforced materials. This way, the system is taking into account foreign materials that can fly out of the fertilizer.

MANURE MANAGEMENT

MACHINES

We offer the best solution for customer with problem solving machines; we are changing the rules of the game with original agricultural solutions in Turkey and around the world; we design the machines of the future by recognizing potential needs. Almost everyone is

trying to make machines but only Çelikel® is doing it differently. CRUISER® is a confidence crushing machine for its competitors with overwhelming desing, superior features! More pressure with each gallon, more progress with each decare!



**EXPORT
VACUUM PUMP**

**EXPORT
GUILLOTINE VALVE**



■ SPREADER

Çelikel Cruiser® is designed to spread liquid by using special angled manure plate. Cruiser's spreading distance can be extended up to 65 meters due to the optionally designed centrifugal pump, which has been designed for tough field conditions and upper spreading.

■ STRONG CHASSIS

A chassis specially designed by Çelikel engineers, supporting a robust Cruiser® body and minimizing fluid movement in the tank, forms the backbone of the machine.

■ FLOAT

Safety is maintained at the highest level in the Cruiser®, and the dual float system prevents liquid from damaging the pump. At the same time, a double float system has been installed to prevent overflow that can happen during the filling process.

CRUISER

IN A CLASS BY ITSELF.

■ PRESSURE AND BAR GAUGES

The pressure and bar indicators used in the CRUISER® make the machine easier to use, allowing the user to start irrigation and vacuuming processes on time. When the pressure gauge shows 1 bar, it means the machine is ready to spray, and when the pressure gauge shows 200 mm / Hg, the machine is ready to vacuum.

■ SCISSOR AXLE STRUCTURE

The Crafter® uses a scissor shaft, which allows flexible operation and minimum pressure on the tractor. The scissor shaft of the Crafter® type is designed so that you can easily use the machine in dented, mounded fields

■ WARNING LAMP

The machine is equipped with flashing lights to prevent potential work accidents. The warning system is placed on top of the CRUISER® so it is visible at night and dark working conditions.



■ WAVE BREAKER

There is a wave breaker system inside the tank of Cruiser® to prevent the liquid from sudden lumping, foaming or upheaval. Thanks to this weight balance inside the machine the threat of rolling over is eliminated.

■ WIDE TYRE

The best time for getting the most of the organic manure is winter and spring when the field and weather conditions are the most challenging. For this matter in Cruiser® manure spreading trailers we used wide and durable tyre to increase the range of movement and maneuver ability.

■ SUSPENSION

With the Cruiser®, Çelikel® engineers developed a robust suspension system that can endure tractor overloads. In this system, deformations that can occur during sudden starts and stops are prevented by transferring the load to the suspension springs in the drawbar.

MANURE MANAGEMENT MACHINES

MACHINES

Çelikel manure management systems are flawless systems to minimize the potential difficulties of the manure collection, dehydration and usage processes of dairy and livestock farms. Regardless of the scale of your business, Çelikel® offers manure management solutions to meet the demands of producers.



Manure separators are at the heart of manure management systems. In order to separate the manure inside the reservoir, it is important that the separator has a long lifespan and runs smoothly. You too can rely on Scud® unconditionally in your fertilizer business.

CARBIDE PLATED
AUGER

STAINLESS
AUGER CORE

LARGE
RESERVOIR

STAINLESS
RESERVOIR

HIGH
SECURITY
PLATFORM

SIEVE
OPTIONS

SCUD4000 SCUD6000

PRODUCT	POWER	SIEVE	AUGER	ÇALIŞMA VOLTAJI	E. PANO-SU
SCUD 6000	5,5 kW	316 Quality Stainless Steel Special Edition	Special hard surface filled 304 Quality stainless steel	220/380 V	Included
SCUD 4000	7,5 kW	316 Quality Stainless Steel Special Edition	316 Quality stainless steel, special solid filling	220/380 V	Included

PRODUCT	ENGINE POWER	PUMP REV	WORKING VOLTAGE	E. PANEL
SCUD MIX 110	11 kW	400 rpm	220/380 V	Included
SCUD MIX 185	18,5 kW	400 rpm	220/380 V	Included
SCUD MIX 220	22 kW	400 rpm	220/380 V	Included

PRODUCT	ENGINE POWER	PUMP REV	WORKING VOLTAGE	E. PANOSU
SCUD PUMP 55	5,5 kW	1400 rpm	220/380 V	Included
SCUD PUMP 75	7,5 kW	1400 rpm	220/380 V	Included
SCUD PUMP 110	11 kW	1400 rpm	220/380 V	Included
SCUD PUMP 185	18,5 Kw	1400 rpm	220/380 V	Included

PRODUCT	TYPE	ENGINE POWER	WHEEL DRIVER NUMBER	SCRAPPER HEIGHT	SCRAPPER WIDTH	ROAD LENGTH
SCUD SCRAPER H	Hydraulic	3-4 kW	1	17 cm	1-5 m	50 m
SCUD SCRAPER C	Chained	1,1 kW	1	17 cm	1-5 m	50 m
SCUD SCRAPER CR	Chained Roped	1,1 kW	1	17 cm	1-5 m	50 m
SCUD SCRAPER R	Roped	0,55 kW	2	17 cm	1-5 m	50 m

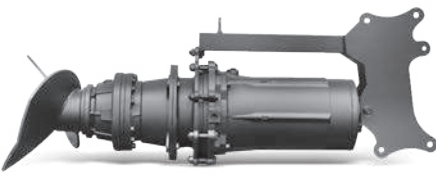

■ MIXER®

Scud Mix® is a specially to mix the clumped manure gathered at the bottom and the liquid manure on top of the manure reservoir. Homogeneously mixed manure will be separated better by the separator.



■ SCUD PUMP®

Scud Pump® is a unique stainless pump which can operate without the use of a chopper thanks to its unique open stainless steel fan system. With its steel cast body it can absorb all impacts coming from outside and will never let you down even in difficult conditions.



■ SCUD SCRAPER®

Scud Scraper® series scrapers have the options to work hydraulically, chained and roped. Thanks to open stainless fan system it works without a chopper. SCUD scapper works perfect regardless of any external shock.

CRAFTER P. 4 - 6 - 8 - 11 - 14 - 18 - 20	X7	X13	X15	X18	X20
LENGTH-A	5890 mm	7395 mm	8120 mm	7725 mm	8355 mm
WIDTH-B	2265 mm	2265 mm	2965 mm	2965 mm	3115 mm
MAX HEIGHT -C	2870 mm	2935 mm	2985 mm	3325 mm	3295 mm
LOADING HEIGHT -D	2450 mm	2500 mm	2620 mm	2960 mm	2930 mm
TYRE TRAIL WIDTH-E	1720 mm	1760 mm	2545 mm	2425 mm	2620 mm
EMPTY WEIGHT	4000 kg	4750 kg	5835 kg	6150 kg	6400 kg
NET MANURE WEIGHT (loading over the top line of the unit)	8900 kg	13200 kg	16000 kg	19500 kg	22000 kg
NET MANURE WEIGHT (COVER LINE)	8250 kg	12500 kg	15000 kg	17500 kg	20000 kg
MAX TOTAL WEIGHT	13250 kg	18620 kg	22335 kg	25650 kg	28400 kg
REQUIRED POWER	60 HP	70 HP	90 HP	120 HP	150 HP
MAX CAPACITY M ³	7,40m ³	11 m ³	13,30 m ³	16,30m ³	17,35 m ³
SPREADER SYSTEM	Vertical Spreader (Swiper)	Vertical Spreader (Swiper)	Vertical Spreader (Swiper)	Vertical Spreader (Swiper)	Vertical Spreader (Swiper)
PTO SPEED	540 rpm (rpm)	540 rpm (rpm)	540 rpm (rpm)	540 rpm (rpm)	540 rpm (rpm)
SPREADING AREA	4...20 m	4...20 m	4...20 m	4...20 m	4...20 m
WHEEL SIZES	400/60 R15,5	400/60 R15,5	550-60.22.5	550-60.22.5	600-50.22.5
THE NUMBER OF WHEELS	2	4	4	4	4
SUSPENSION SYSTEM	FIXED	Tandem	Tandem	Tandem	Tandem
BRAKE SYSTEM	Optional	Optional	Standard	Standard	Standard

CRAFTER P. 4 - 6 - 8 - 11 - 14 - 18 - 20

MANURE DENSITY IS CALCULATED AS 25 TONS/M³.
TECHNICAL VALUES ARE VALID FROM THE DATE OF RELEASE. ÇELİKEL TARIM MAKİNELERİ LTD. ŞTİ. KEEPS THE RIGHTS TO MAKE CHANGES IN TECHNICAL SPECIFICATIONS AND DESIGNS OF THE MACHINES WITHOUT ANY PUBLIC DECLARATIONS RESERVED.

-CRUISER IN A CLASS BY ITSELF.

*MAY VARY ACCORDING TO MANURE DENSITY, SPREADING VALVE BEING OPEN AND INTERIOR PRESSURE.
**IS TRACTOR PTO OUTPUT VALUE. IT MAY VARY ACCORDING TO THE FIELD CONDITION (SLOPE, GROUND TOUGHNESS, GROUND STRUCTURE ETC).
***MAY VARY DEPENDIN ON THE MACHINE OPTIONS.
VALUES ARE BASE MODEL VALUES.
***VACUUM PUMP MODEL AND TECHNICAL SPECIFICATIONS MAY VARY DEPENDING ON THE PRODUCT OR UPPER SPREADER OPTION.
TECHNICAL VALUES ARE VALID FROM THE DATE OF RELEASE.
ÇELİKEL TARIM MAKİNELERİ LTD. ŞTİ. KEEPS THE RIGHTS TO MAKE CHANGES IN TECHNICAL SPECIFICATIONS AND DESIGNS OF THE MACHINES WITHOUT ANY PUBLIC DECLARATIONS RESERVED.

-CRUISER IN A CLASS BY ITSELF.	CRUISER Z3	CRUISER Z5	CRUISER Z10	CRUISER Z20
LENGTH	4350 mm	5880 mm	7670 mm	9500 mm
HEIGHT***	2470 mm	2651 mm	3045 mm	3345 mm
WIDTH***	2000 mm	2150 mm	2617 mm	2525 mm
WEIGHT**	1200 kg	1914 kg	2940 kg	5500 kg
LOADED WEIGHT	4800 kg	8900 kg	14740 kg	28500 kg
WORKING WIDTH *	14 - 20 m	14 - 20 m	16 - 25 m	16 - 30 m
CAPACITY	3000 lt.	5000 lt.	10000 lt.	20000 lt.
MINIMUM POWER REQUIREMENT**	30 kW/40 hp	40 kW/55 hp	52 kW/70 hp	82 kW/110 hp
PTO REV	540 RPM	540 RPM	540 RPM	540 RPM
WHEEL SIZES	12,5/80 15,3	400/60-15,5	550/60-22,5	550/60-22,5
THE NUMBER OF WHEELS	2	2	2	4
AXLE SYSTEM	With Brake	With Brake	With Brake	Tandem Scissor
ROTATING AXLE SYSTEM	-	-	-	Optional
HYDRAULIC BRAKE SYSTEM	Standart	Standart	Standart	Standart
WARNING LIGHTS	Standart	Standart	Standart	Standart
EXTERNAL FILLER CAP	Standart	Standart	Standart	Standart
HYDRAULIC SPREADING VALVE	Standart	Standart	Standart	Standart
MANUEL SUCTION VALVE	Standart	Standart	Standart	Standart
HYDRAULIC SUCTION VALVE	Optional	Optional	Optional	Optional
VACUUM SAFETY VALVE	Standart	Standart	Standart	Standart
PRESSURE SAFETY VALVE	Standart	Standart	Standart	Standart
MANURE SEPARATOR TANK	Standart	Standart	Standart	Standart
INTERIOR TANK SAFETY VALVE	Standart	Standart	Standart	Standart
HYDRAULIC JACK	Standart	Standart	Standart	Standart
LOADING POSITION FRONT LEFT	Standart	Standart	Standart	Standart
LOADING POSITION BACK	Optional	Optional	Optional	Optional
PUMP****	ImporteD (Battioni Pagani Mec 5000)	Import (Battioni Pagani Mec 6500), Import (Moro Kaiser Air Pn 60)	Import (Battioni Pagani Mec 8000), Import (Moro Kaiser Air Pn 70)	Import (Battioni Pagani Mec 13500)
GEOMETRIC PUMP CAPACITY *****	5000 L/min	7000 L/min	8000 L/min	
SUCTION DEPTH *	6 M	6 M	6 M	6 M
AUTOMATIC LOADING	-	-	Optional	Optional
AUTOMATIC LOADING FIXED PIPED	-	Optional	Optional	Optional
LOW LEVEL SPREAD (FOR AREAS WITH TREES 4 inch height)	Standart	Standart	Standart	Standart
LOW LEVEL SPREAD (FOR AREAS WITHOUT TREES 4 inch height)	Optional	Optional	Optional	Optional
CONE SPREAD (FOR AREAS WITHOUT TREES 6 inch height)	Optional	Optional	Optional	Optional
DOUBLE CONE SPREADER	-	Optional	Optional	Optional
SPREAD PIPED (9-12-15-18-21-24m)	Optional	Optional	Optional	Optional
SLIDING PIPED SPREAD BOW (9-12-15m)	Optional	Optional	Optional	Optional
UPPER SPREADER	Optional	Optional	Optional	Optional
UPPER SPREADER RANGE (45° - 5 BAR)*	40 - 60 m	40 - 60 m	40 - 60 m	40 - 60 m
ÜST ATICI AYARLANABİLİR AÇLI	Optional	Optional	Optional	Optional
HİDROLİK ÜST ATICI YÖNLENDİRİCİ	Optional	Optional	Optional	Optional
HİDROLİK ÜST ATICI VANASI	Optional	Optional	Optional	Optional



STEVE BRANDSON

Bosphorus City Atakent Mah. 221. Sk. 34307 Küçükçekmece / İstanbul

dijital@stevebrandson.com www.stevebrandson.com

'The Steve BRANDSON Advertising Agency only serves the people and organizations that think it deserves the best.'

Steve BRANDSON Advertising Agency

Executive President / Steve BRANDSON

Publishing Director / Maximilian MÜLLER

Executive Editor / Daryl MURPHY

Editress / Arzu HOCAOĞLU

3D Visualization Director / Karim MAHMUDOV

Visual Director / Bruce Cheng

Editors / Yasin AKIN, Aykut DAĞ, Burak AYDINLIK

Graphic Designer / Dilara YILMAZ

Photographer / Çağatay KAĞNICI, Levent ODAK

Copyright © 2020 Çelikel Tarım Ltd. Şti. TÜRKİYE

This Catalogue is published under license CELIKEL AGRI CO. LTD. All rights to the licensed title/trademark and concept are owned by CELIKEL AGRI CO. LTD. Reproduction whether in whole or in part without permission of CELIKEL AGRI CO. LTD. is prohibited. The title CELIKEL and the logo there of are registered trademarks of or in trust of CELIKEL AGRI CO. LTD.

Muhir Järkmen
ANISINA



1962

CELİKEL
THE CHOICE OF PROFESSIONAL

3. Organize Sanayi Bölgesi Vali İhsan Dede Cad. No:2 42250 Selçuklu / KONYA

T +90 332 345 15 02 | 444 49 42 | F + 90 332 345 15 04

info@celikeltarim.com | www.celikeltarim.com